

METERING PUMPS

LINC 87TA-11 Series Chemical Metering Pump
Pneumatic Plunger



METERING PUMPS

To Order, Call 800.455.LINC

Or FAX your order anytime to
215.293.0498

For the Nearest Authorized

Representative:

By Telephone: **800.455.LINC** for
the US & Canada, **215.293.0465** or
215.441.0800 for International
customers

By Fax: 215.293.0498

E-mail:

LINCORDER@MILTONROY.com

Technical Support

By Telephone: **800.455.LINC** or
215.293.0498

By E-mail:

INFO@LINCPUMPS.com

Convenient Hours

Our phone lines are open Monday
– Friday 8:00 AM – 4:45 PM (EST)

LINC Warranty

Three year limited warranty on all our
products against defects in materials.

LINC Technical Support

Technical service and support
begins with an easy toll-free call.
Many times, our experienced
customer service reps can isolate
and resolve problems over the
phone or provide a referral to our
authorized representatives nation-
wide. We also offer factory repair
services with facilities in Ivyland,
PA. if a warranty issue that cannot
be resolved locally.

Purchase Orders

All mail-in purchase orders must
be signed by an authorized
person. When ordering please list:

- Quantity
- Description of Items
- Shipping Address
- Billing Address
- Purchase Order Number

Request for Quotation – RFQ's

Please send RFQ's to:

By Mail:

Linc Milton Roy
Attn: Customer Service
201 Ivyland Road
Ivyland, PA 18974
USA

By Fax:

1.215.293.0498

By E-mail:

Lincorders@miltonroy.com

Freight Charges

All shipments are F.O.B., Ivyland,
PA, USA. Shipping and handling
are included on the invoice,
prepay and add.

Terms

With credit approval, net 30 days.

METERING PUMPS

Contents – 87TA-11 Pump Manual	Page
General Specifications	4
Selection Chart	4
Ordering Chart	4
Scope Of This Manual.	5
Installation	5
Maintenance	5
Removing the Pump from Service	5
Timer.....	6
Check Valves	6
Piston Plunger Assembly	6
Pressure Seal	6
Seal Lubrication	7
How To Determine Supply Pressure	7

Assembly Drawings & Parts Lists

Figure 1, 87TA-11 Assembly Drawing	8
Pump Assembly Parts List: 87TA-11	9
Figure 2, “T” Series Timer Assembly Drawing	10
“T” Series Timer Parts List	10
Figure 3, Discharge Check Valve Assembly Drawing	11
Discharge Check Valve Parts List	11
Figure 4, Suction Check Valve Assembly Drawing	11
Suction Check Valve Parts List	11
LINC Chemical Pump Gas Consumption Chart.....	12

METERING PUMPS

PNEUMATIC PLUNGER

General Specifications: 87TA Series Pneumatic Metering Pumps

Wetted Parts:

Pump Body:	316 Stainless Steel
Plunger:	17 - 4 PH Stainless Steel or Ceramic
Plunger Seal:	Refer to Ordering Chart

Check Valves :

Body:	316 Stainless Steel
Ball:	Carbide
Spring - Discharge:	316 Stainless Steel

Pneumatic Section:

Piston Housing:	303 Stainless Steel
Timer:	303 Stainless Steel

Plunger Sizes: 1/4" plunger diameter

Pressure: To 2,500 psi, maximum

Optional Materials: Hastelloy, Monel, & Titanium

The LINC 87TA Series: Pneumatic, Plunger-Type Metering Pump Selection Chart

Model Number	Plunger Diameter	Piston Diameter	Maximum Rate Gal/Hr	Maximum Rate Liter/Hr	Minimum Rate Gal/Hr	Minimum Rate Liter/Hr	Maximum Pressure psi ⁶	Maximum Pressure bar ⁶	Theoretical Amp. Ratio	Strokes Per Minute	Volume Per Stroke	Stroke Length
87TA-11-x1	1/4"	1 1/2"	0.76	2.88	0.006	0.024	2,500	172	36:1	4 - 60	0.80 cc	1"

Notes:

1. Maximum rates are based on 60 strokes per minute
2. Minimum rates are calculated on 1/8" stroke length and a minimum of 4 strokes per minute.
3. The timer supply pressure is 15 to 100 psi.
4. Wetted O-Rings are TFE.
5. When creating a Model Number, using the Ordering Chart, the "x" in the Model Number column above will be replaced by a single digit representing the plunger seal selection. The plunger seal is shown in the Ordering Chart.
6. Maximum pressure based on 100psi supply pressure.

Ordering Chart: LINC 87TA Series Pneumatic Plunger Metering Pump

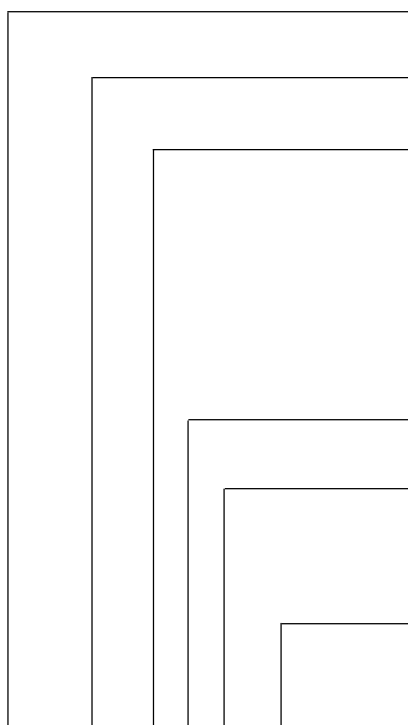

Series:

87TA - Pneumatic, plunger-type metering pump

Plunger:

11 - 1/4" plunger diameter

Plunger Seal:

- 1 - Packing mechanical seal - Fluorocarbon, wetted o-rings - TFE
- 2 - Packing mechanical seal - Fluoromyte, wetted o-rings - TFE
- 3 - Packing mechanical seal - Nitrile, wetted o-rings - TFE
- 4 - Packing mechanical seal - TFE/Graphite, wetted o-rings - TFE
- 5 - Specify your requirements
- 6 - Packing mechanical seal - Ultra High Molecular Weight Polyethylene, wetted o-rings - TFE
- 7 - O-rings packing seal - Fluorocarbon, wetted o-rings, TFE
- 8 - O-rings packing seal - Nitrile, wetted o-rings - TFE
- 9 - O-rings packing seal - Kalrez, wetted o-rings - Kalrez

Piston Size:

1 - 1 1/2" - piston diameter

Other:

- 4 - Ceramic
- 5 - Specify your requirements
- 9 - All 316 ss pump/timer

Option Number:

() - Factory will assign an option number based on specified requirements.

Note: If no further requirements are desired, omit "Other" options codes from the part number.
Example 87TA-11-41.

LINC 87TA- _____ - _____ ()

Example: LINC 87TA-11-41 Pneumatic Metering Pump

METERING PUMPS

PNEUMATIC PLUNGER

Scope Of This Manual:

This manual describes the LINC 87TA Chemical Metering Pump by providing operating instructions and listing the available parts. This pump is a pneumatically operated plunger pump.

Installation:

This pump requires a flooded suction and must be installed lower than the chemical supply tank. Vertical installation of the pump is required.

1. Connect the suction line, through a strainer, or filter to the suction check valve (fig. 1, item 14).
2. Connect the discharge line to the discharge check valve (fig. 1, item 13).

Note: An in-line check valve P/N 25019 at the point of injection is recommended to prevent back flow to the pump during shutdown or routine maintenance.

3. Connect the air supply pressure line to the timer port marked "IN" (fig. 1, labeled Supply Pressure). Air is the recommended supply; however, any dry filtered gas may be used. The supply pressure to the timer must be regulated between 15 and 100 psig.
4. Set the regulator output pressure to overcome the

discharge pressure required by the pump. Refer to the paragraph on "How To Determine Supply Pressure" located in this section of this manual for information on determining the correct supply pressure.

5. To prime the pump, loosen the bleed plug (fig. 1, item 15). The bleed plug has barbs, allowing you to slip a hose over it, to bleed gas or liquid to a safe location. Allow the liquid to flow into the pump chamber, venting the trapped air. Tighten the bleed plug.
6. Start the pump and run for a minimum of one minute. Open the bleed screw again and evacuate all the remaining air or gas from the pump chamber.
7. The stroke rate is changed by rotating the knob on the timer. Rotate the knob clockwise to increase the stroke rate, counterclockwise to decrease the stroke rate.
8. The stroke length is changed by rotating the volume adjustment screw (fig. 1, item 1) located on top of the piston housing. Loosen the jam nut (fig. 1, item 2) and rotate the volume adjustment screw as necessary. The minimum stroke length is 1/8".

Maintenance:

Refer to the sectional drawings in this manual before proceeding. All repairs should be performed in a clean environment.

Removing The Pump From Service:

1. Rotate the control knob on the timer to the "0" position.
2. Disconnect the supply pressure from the timer.
3. Close the upstream and downstream valves on the chemical lines.
4. Open the bleed plug to release pressure (fig. 1, item 15).
5. Disconnect the suction and discharge lines from the check valves.

Timer, Figure 1, item 16 and Figure 2:

1. Disconnect the supply pressure from the timer.
2. Rotate the timer counterclockwise on the pipe nipple that connects it to the piston housing until the timer is vertical with the supply pressure port pointing down.
3. Loosen and remove the two screws from the timer (fig. 2, item 1).
4. Separate the three timer sections and discard the seal, diaphragm and the disc (fig. 2, items 4, 6 & 15). Be careful not to lose the small disc

METERING PUMPS

P N E U M A T I C P L U N G E R

spring (fig. 2, item 16). Note the orientation of the diaphragm as it is removed.

5. Loosen the set screw on the knob (fig. 2, item 11). Remove the knob and knob spring (fig. 2, item 9).
6. Unscrew the adjustment screw (fig. 2, item 10) from the front body (fig. 2, item 13). Remove and discard the o-ring (fig. 2, item 12).
7. Reassemble the timer in reverse order of the above steps, using new rubber parts. Lubricate the adjustment screw threads and its o-ring. No other lubrication is required.
8. After installing the adjustment screw, turn it in by hand without the knob installed until it lightly seats. During this operations do not over-tighten the adjustment screw into its seat. Apply supply pressure to the timer and unscrew the adjustment screw slowly until the pump starts to run. Trial and error will be necessary to determine the proper orientation of the knob on the adjustment screw. Once the proper orientation is determined, re-install the knob spring and knob.

Check Valves, Figure 1, items 13 & 14, Figures 3 & 4:

Note: Field repair is not recommended because of potential contamination. These assemblies should be replaced in the field, then serviced in the shop. Check valves feature a two-piece construction for easy repair.

1. Separate the two halves of the check valve (fig. 3 & 4, items 1 & 4).
2. Replace the o-rings, ball, and spring as required (fig. 3 & 4, items 2, 3, 5 & 6). During this procedure, extreme care should be exercised. The ball should be "peened" on the Teflon seat to ensure proper sealing (fig. 4, items 5 & 2).
3. Ensure that the proper flow direction, as marked on the valve body, is observed when installing or replacing the check valves.

Piston Plunger Assembly, Figure 1, Items 4, 5, 6, 9, & 10

1. Loosen the screws (fig. 1, item 8) on the piston housing (fig. 1, item 3).
2. Grasp the piston housing and pull up to remove.
3. Grasp the piston (fig. 1, item 4) and pull away from the center housing to remove. Inspect the plunger for wear, especially longitudinal

grooves. Replace if necessary. Inspect the piston u-cup (fig. 1, item 5).

Replace if necessary.

4. Remove the spring, lubricant seal retainer, and lubricant seal from the spring cavity (fig. 1, items 6, 9, & 10). Replace the lubricant seal (o-ring).
5. Lubricate the seal and piston assembly with oil to protect against possible damage during assembly.
6. Reassemble the piston plunger assembly and install into the center housing. See Figure 1 for correct assembly.
7. Install the piston housing and secure with screws.
8. Reinstall the timer assembly.

Pressure Seal:

1. Separate the pump body assembly (fig. 1, item 7), by unscrewing the lower housing from the center housing. These are straight threads and should come apart easily
2. Remove the seal, or seal and back-up (fig. 1, item 12).
3. Install the new seal into the lower housing, o-ring or lip side down. If your pump includes a back-up for the seal, be sure to replace it as well.
4. Install the lower housing into the center housing, and screw them back together snugly.

METERING PUMPS

P N E U M A T I C P L U N G E R

Seal Lubrication:

1. Remove the plug from the center housing of the pump (fig. 1, item 11).
2. Inject approximately 0.5 cc of silicone base grease (Dow Corning DC-7, part #10354) to the pump.

Note: Do not use a grease gun or any metal tool to insert the grease into the pump.

3. Replace the plug and tighten sufficiently to prevent loosening during operation.
4. Silicone grease should be added approximately every 4-6 weeks depending upon operating conditions.

IMPORTANT: How To Determine Supply Pressure:

For best results and longer pump life, it is recommended that a pressure regulator be used upstream of the pump in order to properly adjust the supply pressure. The supply pressure to the pump should be a minimum of 15 psig and a maximum of 100 psig.

The theoretical "amplification ratio" of the shown in the specifications chart: however in actual application many factors will affect the specific pressure required to achieve the desired discharge volume at specific pipeline conditions. (ie: Stroke Rate, Fluid Viscosity, Gas Quality, Temperature, etc.) Proper balancing of air or gas supply pressure against the performance requirement will provide longer pump life and reduce maintenance; therefore we recommend that you perform some test at your specific conditions to determine what supply pressure will be required to provide the chemical injection that you desire. To determine the approximate supply pressure divide the required discharge pressure by the amplification ratio for the pump and add 20 psi to the result.

Note: The discharge pressure of the 87TA should never exceed 2,500 psig.

METERING PUMPS

P N E U M A T I C P L U N G E R

Figure 1, 87TA Series Pneumatic Metering Pump

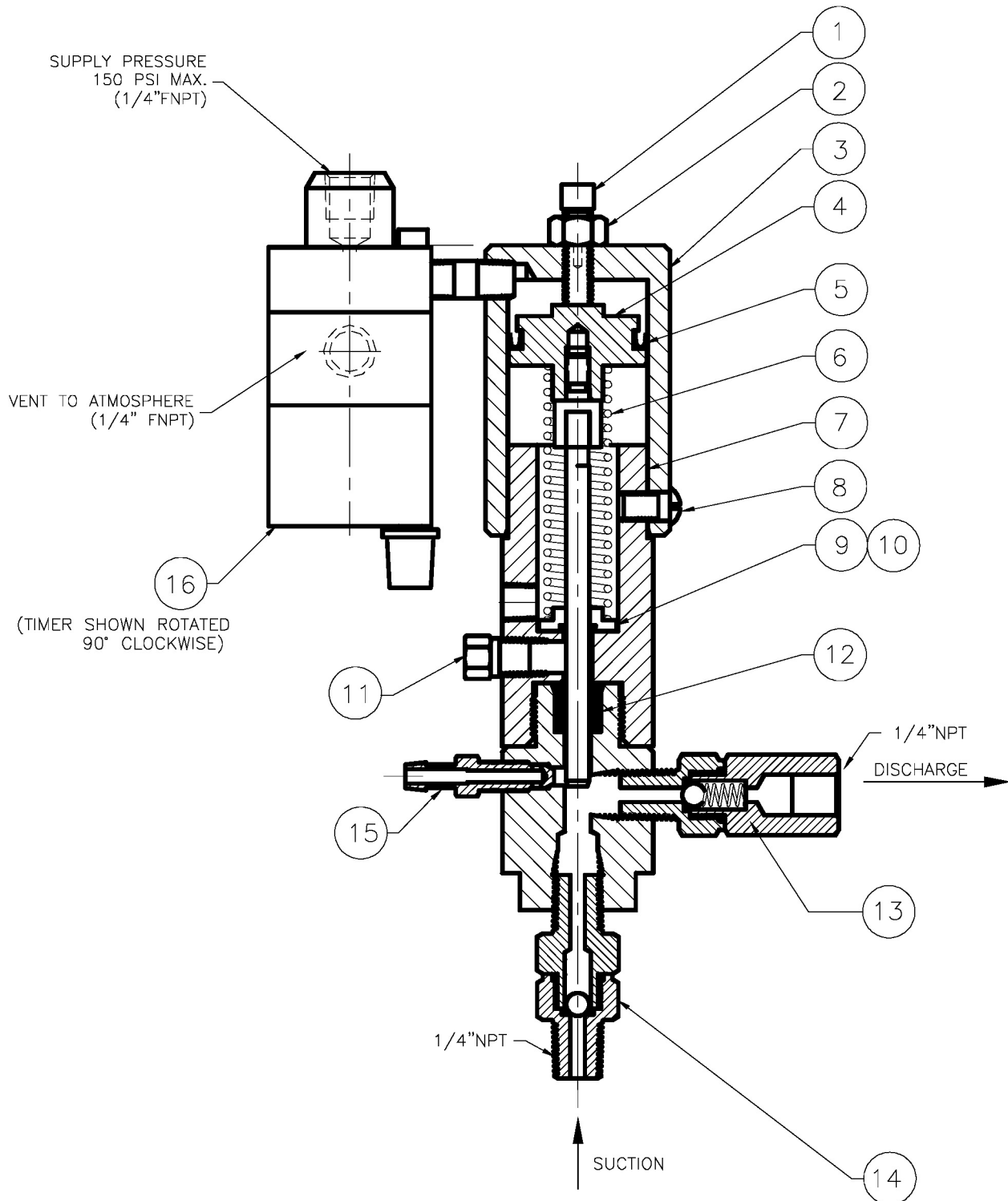

METERING PUMPS

P N E U M A T I C P L U N G E R

LINC 87TA Series Metering Pump Parts List

Model	LINC 87TA-11-X1			
Plunger Size	1/4"			
Piston Size	1 1/2"			
Item	Part #	Description	Material	Qty
1	11812	Stroke Adjustment Screw	18-8 ss	1
2	11466	Lock Nut	18-8 ss	1
3	25378	Piston Housing	303 ss	1
4	23141	Piston Assembly (17-4 Ph Plunger)	303 ss/17-4 Ph ss	1
4a	24646	Piston Assembly (Ceramic Plunger)	Ceramic	1
5	11388	Piston U-Cup	Nitrile	1
6	10448	Plunger Return Spring	17-7 Ph ss	1
7	31829	Center/Lower Housing Assembly	316 ss/316 ss	1
8	13377	Piston Housing Screw	18-8 ss	3
9	23142	Retainer	Acetal	1
10	11242	O-Ring 202	Fluorocarbon	1
11	10278	Lubricant Plug	304 ss	1
12		Plunger Seal (See Chart Below)		1
13	24751	Discharge Check Valve	316ss See Figure 3	1
14	22879	Suction Check Valve	316ss See Figure 4	1
15	20460	Bleed Screw	316 ss	1
16	31668	Pneumatic Timer	See Figure 2	1

Item 12 -- Seal				
Pump Model	Seal Part #	Seal Material	Back Up Part #	Qty
87TA-11-11	10024	Fluorocarbon	22571	1
87TA-11-21	21197	Fluoromyte	22571	1
87TA-11-31	10464	Nitrile	22571	1
87TA-11-41	11821	TFE/Graphite	N.A.	1
87TA-11-61	13007	UHMWPE	N.A.	1

METERING PUMPS

P N E U M A T I C P L U N G E R

Figure 2, Timer

Reference fig. 1 item 16

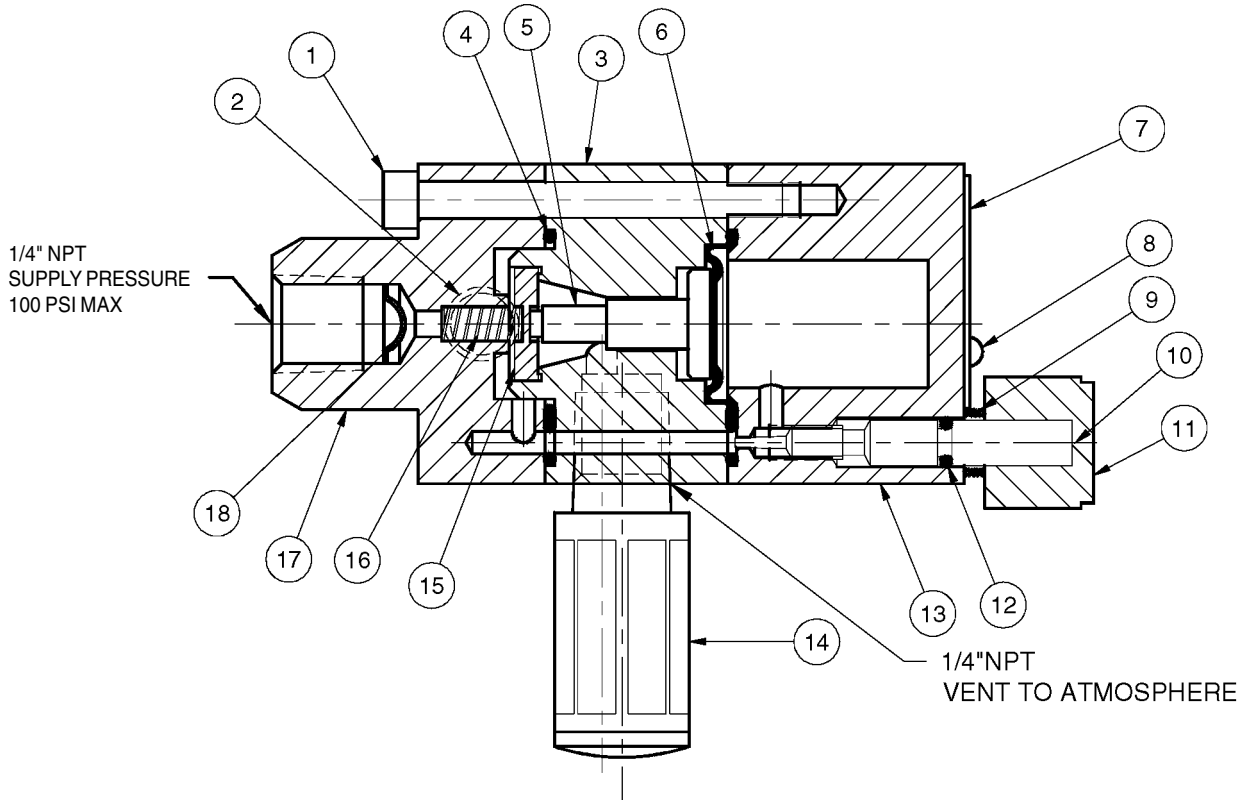

Assembly Item	31668 Part #	Timer Description	Material	Qty
1	13223	Screw	18-8 ss	2
2	25130	Hex Nipple	303 ss	1
3	31664	Center Body	303 ss	1
4	13227	Seal	Nitrile	1
5	13247	Disc Actuator	Delrin	1
6*	13226	Diaphragm	Nitrile	1
7	13246	Nameplate	18-8 ss	1
8	10324	Drive Screw	18-8 ss	2
9	13253	Knob Spring	Stainless steel	1
10	25149	Adjustment Screw	303 ss	1
11	13243	Knob	Polycarbon	1
12	10326	O-Ring	Nitrile	1
13*	31663	Front Body	303 ss	1
14	12952	Muffer		1
15	13225	Disc	Aluminum/Nitrile	1
16*	13222	Disc Spring	Stainless Steel	1
17	31665	Rear Body	303 ss	1
18*	10244	Screen	Stainless steel	1
*	25183	Timer Repair Kit		1

METERING PUMPS

P N E U M A T I C P L U N G E R

Figure 3, Discharge Check Valve
Reference fig. 1, item 13

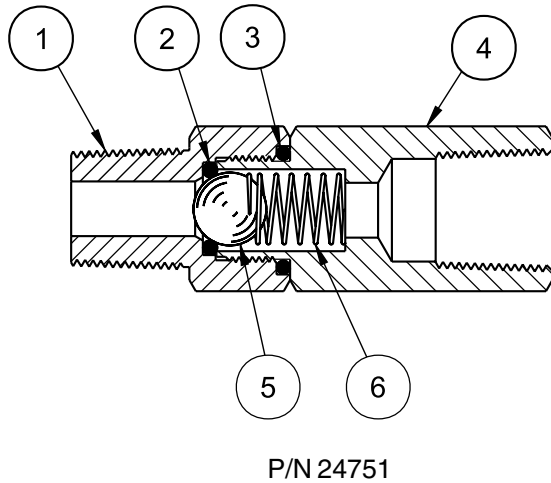
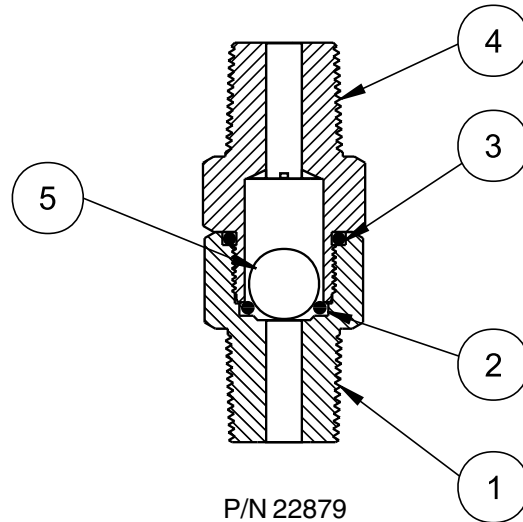

Figure 4, Suction Check Valve
Reference fig. 1, item 14



Assembly	24751	Discharge Check Valve - Two-Piece Body		Port Size 1/4" NPTF
Item	Part #	Description	Material	Qty
1	23257	Inlet Body	316 ss	1
2	10313	Seat 009	TFE	1
3	11485	Seal 013	Fluorocarbon	1
4	24755	Outlet Body	316 ss	1
5	13276	Ball 9/32"	Carbide	1
6	11438	Spring	316 ss	1

Assembly	22879	Suction Check Valve - Two-Piece Body		Port Size 1/4" NPTM
Item	Part #	Description	Material	Qty
1	23257	Inlet Body	316 ss	1
2	10313	Seat 009	TFE	1
3	11485	Seal 013	Fluorocarbon	1
4	23256	Outlet Body	316 ss	1
5	13276	Ball 9/32"	Carbide	1

METERING PUMPS

LINC Chemical Pump Gas Consumption Table

ACTUATION PISTON DIA. (IN)>>	1.50	2.25	3	4	4	4	6	8	10
>> CONFIGURATION >>	SPRING RETURN NO RELAY	SPRING RETURN NO RELAY	SPRING RETURN NO RELAY	SPRING RETURN NO RELAY	SPRING RETURN INCLUDING RELAY	GAS RETURN INCLUDING RELAY	GAS RETURN INCLUDING RELAY	GAS RETURN INCLUDING RELAY	GAS RETURN INCLUDING RELAY
SUPPLY PRESS. (PSI)	VOLUME DISPLACED BY PISTON FOR 1" STROKE(CUBIC FEET)								
	0.00102265	0.00230097	0.00409062	0.00727221	0.00727221	0.01454441	0.03272492	0.05817764	0.09090257
	THEORETICAL GAS CONSUMPTION FOR EACH 1" STROKE (SCF)								
0	0.0000	0.0000	0.0000	0.0000	0.0000	0.0000	0.0000	0.0000	0.0000
10	0.0017	0.0039	0.0069	0.0122	0.0122	0.0244	0.0550	0.0978	0.1527
20	0.0024	0.0054	0.0097	0.0172	0.0172	0.0343	0.0772	0.1373	0.2146
30	0.0031	0.0070	0.0124	0.0221	0.0221	0.0442	0.0995	0.1769	0.2764
40	0.0038	0.0086	0.0152	0.0271	0.0271	0.0541	0.1218	0.2165	0.3383
50	0.0045	0.0101	0.0180	0.0320	0.0320	0.0640	0.1440	0.2561	0.4001
60	0.0052	0.0117	0.0208	0.0370	0.0370	0.0739	0.1663	0.2956	0.4619
70	0.0059	0.0133	0.0236	0.0419	0.0419	0.0838	0.1886	0.3352	0.5238
80	0.0066	0.0148	0.0264	0.0468	0.0468	0.0937	0.2108	0.3748	0.5856
90	0.0073	0.0164	0.0291	0.0518	0.0518	0.1036	0.2331	0.4144	0.6474
100	0.0080	0.0180	0.0319	0.0567	0.0567	0.1135	0.2553	0.4539	0.7093
110	0.0087	0.0195	0.0347	0.0617	0.0617	0.1234	0.2776	0.4935	0.7711
120	0.0094	0.0211	0.0375	0.0666	0.0666	0.1333	0.2999	0.5331	0.8330
130	0.0101	0.0226	0.0403	0.0716	0.0716	0.1432	0.3221	0.5727	0.8948
140	0.0108	0.0242	0.0430	0.0765	0.0765	0.1531	0.3444	0.6123	0.9566
150	0.0115	0.0258	0.0458	0.0815	0.0815	0.1630	0.3667	0.6518	1.0185