

INSTRUCTION MANUAL

M E T E R I N G P U M P S

LINC84T-13 Series Chemical Metering Pump
Pneumatic Plunger



METERING PUMPS

ORDERING & SERVICE

To Order, Call 800.455.LINC

Or FAX your order anytime to
215.293.0498

For the Nearest Authorized

Representative:

By Telephone: **800.455.LINC** for
the US & Canada, **215.293.0465** or
215.441.0800 for International
customers

By Fax: 215.293.0498

E-mail:

LINCORDER@MILTONROY.com

Technical Support

By Telephone: **800.455.LINC** or
215.293.0498

By E-mail:

INFO@LINCUMPS.com

Convenient Hours

Our phone lines are open Monday
– Friday 8:00 AM – 4:45 PM (EST)

LINC Warranty

Three year limited warranty on all our
products against defects in materials.

LINC Technical Support

Technical service and support
begins with an easy toll-free call.
Many times, our experienced
customer service reps can isolate
and resolve problems over the
phone or provide a referral to our
authorized representatives nation-
wide. We also offer factory repair
services with facilities in Ivyland,
PA. if a warranty issue that cannot
be resolved locally.

Purchase Orders

All mail-in purchase orders must
be signed by an authorized
person. When ordering please list:

- Quantity
- Description of Items
- Shipping Address
- Billing Address
- Purchase Order Number

Request for Quotation – RFQ's

Please send RFQ's to:

By Mail:

Linc Milton Roy
Attn: Customer Service
201 Ivyland Road
Ivyland, PA 18974
USA

By Fax:

1.215.293.0498

By E-mail:

Lincorders@miltonroy.com

Freight Charges

All shipments are F.O.B., Ivyland,
PA, USA. Shipping and handling
are included on the invoice,
prepay and add.

Terms

With credit approval, net 30 days.

METERING PUMPS

T A B L E O F C O N T E N T

Contents - 84T-13 Pump Manual	Page
General Specifications	4
Selection Chart	4
Ordering Chart.....	4
Scope Of This Manual	5
Installation	5
Maintenance	5
Removing the Pump from Service	5
Timer.....	6
Relay	6
Suction Check Valve.....	6
Discharge Check Valve	6
Piston/Plunger.....	7
Plunger Seal	7
Reassembling The Pump	7
How to Determine Supply Pressure	8
Assembly Drawings & Parts Lists	
Figure 1, 84T-13 Assembly Drawing	9
Pump Assembly Parts List: 84T-13	10
Plunger Seal Materials Parts List	11
Figure 2, "T" Series Timer.....	12
Figure 3, Single Acting Relay	13
Figure 4, Discharge Check Valve.....	14
Figure 5, Suction Check Valve	15
LINC Chemical Pump Gas Consumption Chart	16

METERING PUMPS

P N E U M A T I C P L U N G E R

General Specifications: LINC84T-13 Series Pneumatic, Plunger Type Metering Pumps	
Wetted Parts:	
Pump Body:	316 Stainless Steel
Plunger:	17-4 PH or Ceramic
Plunger Seal:	Refer to Ordering Chart
Check Valves :	
Body:	316 Stainless Steel
Ball:	Carbide
Spring - Discharge:	316 Stainless Steel
Seat:	TFE
Pneumatic Section:	
Piston Housing:	303 Stainless Steel
Timer:	303 Stainless Steel
Plunger Sizes:	1/2" plunger diameters
Pressure:	To 9,000 psi, maximum
Optional Materials:	316 Stainless Steel, Hastelloy, Monel, & Titanium

The LINC 84T -13 Series: Pneumatic, Plunger-Type Metering Pump Selection Chart												
Model Number	Plunger Diameter	Piston Diameter	Maximum Rate Gal/Hr	Maximum Rate Liter/Hr	Minimum Rate Gal/Hr	Minimum Rate Liter/Hr	Maximum Pressure psi	Maximum Pressure bar	Amp. Ratio	Strokes Per Minute	Volume Per Stroke	Stroke Length
1" Plunger with Timer/Relay												
84T-13-x4	1/2"	4"	2.2	8:3	0.03	0.10	9,000	610	60:1	4 - 45	3.2 cc	1"

Notes:

- Maximum rates are based on maximum strokes per minute per pump.
- Minimum rates are calculated as follows:
1/2" plunger pumps are 1/4" stroke length and a minimum of 4 strokes per minute.
- The timer supply pressure is 15 to 100 psi.
- The relay supply pressure range is 50 to 150 psi.
- When creating a Model Number using the Ordering Chart, the "x" in the Model Number column above will be replaced by a single digit representing the plunger seal selection. The plunger seal is shown in the Ordering Chart.

Ordering Chart: LINC 84T-13 Series Pneumatic Plunger Metering Pump

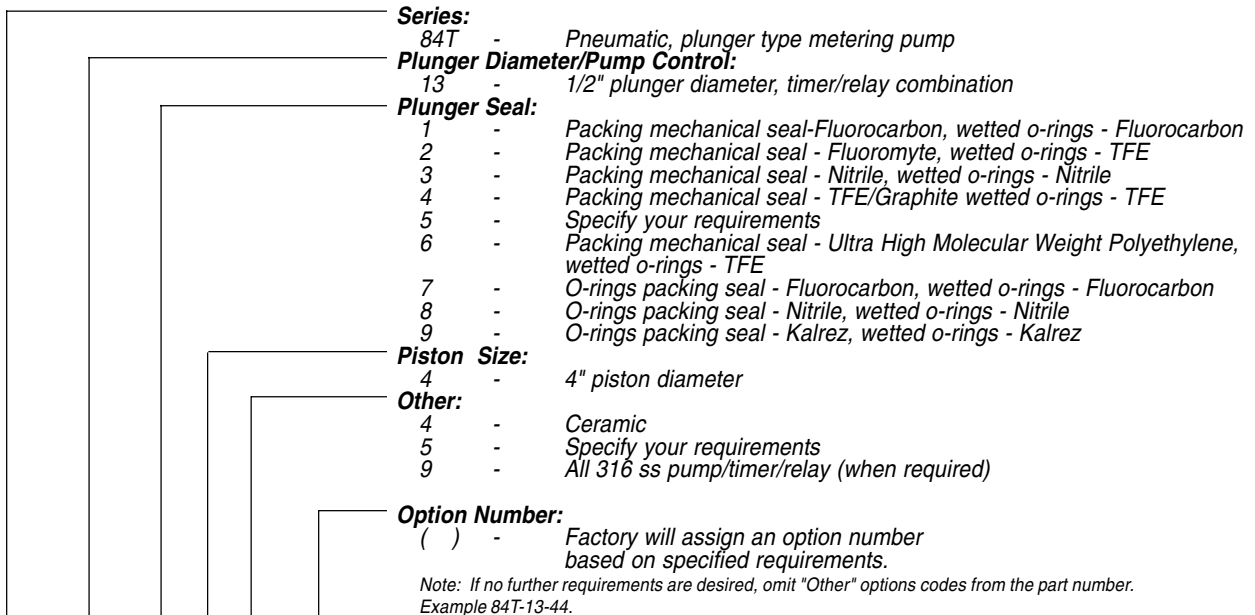

LINC 84T-_____ - _____ ()
Example: LINC 84T-13-44 Pneumatic Metering Pump

METERING PUMPS

PNEUMATIC PLUNGER

Scope Of This Manual:

This manual describes and provides instructions and parts list for the LINC84T-13 Series Chemical Metering Pump. This pump is a pneumatically operated plunger pump.

Installation:

The LINC84T-13 pump requires a flooded suction and must be located lower than the chemical supply tank. Vertical installation of the piston housing is required.

1. Connect the suction line through a filter or strainer to the suction check valve (fig. 1, item 19).
2. Connect the discharge line from the discharge check valve to the desired location (fig. 1, item 18).

Note: An in-line check valve at the point of injection is recommended to prevent back blow to the pump during shutdown or servicing.

3. Connect the supply pressure to both the timer and the relay (fig. 1, items 1 & 3). Air is the recommended supply; however, any dry filtered gas may be used. The supply to the timer and relay must be separate. Two filter-regulators are required, one to control the supply pressure to the timer and another to control the supply pressure to the relay.

4. Using the regulator that feeds the supply to the relay, set the supply pressure to overcome the discharge pressure of the pump. To do this, divide the discharge pressure by the Amplification Ratio and add approximately 10 psi to ensure positive injection of the chemical. Refer to "How To Determine Supply Pressure," in this section of the manual.
5. Assure that the control knob on the timer is set so that the pump will not stroke over 45 strokes per minute.
6. Slowly increase the supply to the timer, using the regulator that feeds the timer, until the pump begins to stroke smoothly. This pressure should be in the 20 to 40 psig range depending on the supply to the relay.
7. To prime the pump, loosen the bleed screw (fig. 1, item 21) allowing the liquid (chemical) to flow into the pump chamber, venting the trapped air or gas.
8. After the liquid exits, tighten the bleed screw and start the pump and run for a minimum of one minute. Open the bleed screw again and evacuate all the remaining air or gas from the pump chamber.
9. Using a rate gauge, set the desired pumping rate by adjusting the timer knob and

stroke adjustment screw. The timer can be set to stroke the pump from 4 strokes/minute to the maximum rate of 45 strokes/minute.

10. The stroke length is adjusted by rotating the stroke adjustment screw (fig. 1, item 7) on top of the piston housing (fig. 1, item 9). Loosen the jam nut and adjust the stroke adjustment screw as necessary (fig. 1, item 8). Lock down the jam nut after any adjustments are made.

Note: The minimum stroke on the 84T-13 is 1/4".

Maintenance:

Refer to all sectional drawings and parts list in this manual. All repairs should be performed in a clean environment.

The following steps must be taken before proceeding with any maintenance operations:

Removing the Pump from Service:

1. Rotate the control knob on the timer to the "O" position.
2. Disconnect the supply pressure from the timer and relay.
3. Close the upstream and downstream valves on the chemical lines.
4. Open the bleed screw to release the pressure in the pump check valves.

METERING PUMPS

PNEUMATIC PLUNGER

5. Disconnect the suction and discharge lines from the check valves.

Timer, Figure 1, item 1 & Figure 2:

1. Disconnect the supply pressure from the timer.
2. Disconnect the timer from the pipe nipple (fig. 1, item 24) that connects to the relay.
3. Loosen and remove the two screws from the timer (fig. 2, item 1).
4. Separate the three timer sections and discard the seal disc and diaphragm (fig. 2, items 4, 15, & 6). Be careful not to lose the small disc spring (fig. 2, item 16). Note the orientation of the diaphragm as it is removed.
5. Loosen the set screw on the knob (fig. 2, item 11). Remove the knob and knob spring (fig. 2, items 11 & 9)
6. Unscrew the adjustment screw (fig. 2, item 10) from the front body (fig. 2, item 13). Remove and discard the o-ring (fig. 2, item 12).
7. Reassemble the timer in reverse order of the above steps using new rubber parts. Lubricate the adjustment screw threads and its o-ring. (fig. 2, item 12).
8. After installing the adjustment screw, turn it in by hand, with out the knob installed, until it lightly seats. During this operation do not over tighten the adjustment screw into its seat. Apply supply pressure

to the timer and unscrew slowly until the pump starts to run. Trial and error will be necessary to determine the proper orientation of the knob on the adjustment screw. Once the proper orientation is determined, reinstall the knob spring and knob.

Relay, Fig. 1, item 3 & Fig. 3:

1. Disconnect the supply pressure from the relay.
2. Unscrew the relay from the nipple (fig. 1, item 4)..
3. If the relay is not functioning properly and/or is leaking the parts in the repair kit # 25182 replaced (fig. 3, items 6, 11, 12, & 13). This repair kit consists of two o-rings, a piston seal, spring and a poppet.
4. Remove the four socket cap screws (fig. 3, item 10) that hold the lid on the relay. Note the location of all ports so that location can be the same when the unit is reassembled. Separate the body parts and the lid. Remove the lock nut (fig. 3, item 3) which will allow each individual part to be inspected. Replace the old parts with the parts from the new repair kit and reassemble. Special care should be taken so that each part, especially the piston spacer and the seal poppet (fig. 3, items 5 & 6), is put back into the same location when reassembling.

5. To test the relay prior to reassembly, connect the supply pressure to the port marked "IN." Supply pressure should be routed to the port marked "OUT" with no leakage to the port marked "E."
6. Reinstall the timer & relay on the pump housing (fig. 1)

Suction Check Valve,

Figure 1, item 19 & Figure 5:

1. Disconnect the piping from the check valve.
2. Unscrew the check valve body from the pump (fig. 5, item 1).
3. Remove and discard the o-rings (fig. 5, items 3 & 4).
4. Inspect the ball for damage (fig. 6, item 2). Replace if necessary. Reassemble the check valve using new o-rings. If the seat o-ring is Teflon, install it onto the check valve body and "peen" the ball into the seat to ensure proper sealing (fig. 5 item 1).
5. Install the repaired suction check valve into the pump body. Tighten securely.

Discharge Check Valve,

Fig. 1, item 18 & Fig. 4:

1. Disconnect the piping from the check valve.
2. Unscrew the check valve body from the pump (fig. 4, item 1).
3. Remove and discard the o-rings (fig. 4, items 4 & 5).
4. Inspect the ball and spring for damage (fig. 4, items 2 & 3).

METERING PUMPS

PNEUMATIC PLUNGER

Replace if necessary. Reassemble the check valve using new o-rings. If the seat o-ring is Teflon, install in onto the pump body assembly and "peen" the ball onto the seat to ensure proper sealing (fig. 1, item 20).

5. Install repaired discharge check valve into the pump body. Place the ball on the o-ring seat followed by the spring (small end of the spring toward the ball) and screw the discharge check valve body into the pump body assembly. Tighten securely.

Piston/Plunger, Figure 1, item 10:

1. Secure the pump body in a vise
2. Remove the timer & relay assembly from the piston housing (fig. 1, item 3).
3. Remove the piston housing screws (fig. 1, item 13) Grasp the piston housing and pull up to remove and pull up to remove (fig. 1, item 9).
4. Grasp the piston and pull away from the pump body assembly to remove (fig. 1, item 10) Inspect the plunger for wear, especially longitudinal grooves. Replace the piston assembly if necessary.

Plunger Seal, Figure 1, item 17A:

1. With a pipe or strap wrench, separate the pump body, separate the pump body assembly (fig. 1, item 20).

2. Carefully remove the plunger seal and plunger seal back up from the upper housing of the pump body assembly. (fig. 1, Item 17A and 17B). Inspect for wear or deterioration from being attacked by the chemical being pumped.
3. Replace the plunger seal. If needed, also replace the plunger seal backup. Extreme care should be taken not to scratch or distort these parts.

Reassemble the Pump:

1. Lubricate the piston u-cup and plunger with light oil to protect against possible damage during assembly.
2. Reassemble the piston/plunger assembly which includes the lubricant seal, lubricant seal back-up and spring and install into the pump body assembly. See Figure 1 for correct assembly.
3. Replace the piston housing and secure with the piston housing screws.
4. Install the new split bushing and plunger seal. See the procedure entitled "Plunger Seal" above.
5. Screw the upper part of the pump body assembly back into the lower part and tighten securely.
6. If the bleed screw has been removed, install and tighten securely.

Plunger and Plunger Seal Lubrication:

1. Remove the plug from the pump body (fig. 1, item 16).
2. Add silicone base lubricant (Dow Corning DC-7, part #10354) or equal into the port where the plug was removed. Approximately 0.5 cc will be required for each refill. Replace the plug.

Note: Do not use a grease gun or any metal tool to insert the lubricant into the pump to prevent damage to the plunger or plunger seal.

3. Silicone lubricant should be added every 4 - 6 weeks depending upon operation conditions.

METERING PUMPS

P N E U M A T I C P L U N G E R

IMPORTANT: How To Determine Supply Pressure:

The theoretical amplification ratio shown in the Selection Chart of this manual is the area of the piston divided by the area of the plunger. This amplification ration is used to determine how much gas supply pressure is required to enable the pump to generate the required liquid discharge pressure. The theoretical gas supply pressure required to generate a specific liquid discharge pressure is calculated by dividing the required liquid pressure by the amplification ratio. However, the amplification ratio is a theoretical number and in an actual application, other factors such as friction and stroke rate require that a higher gas supply pressure be used.

To determine the approximate gas supply pressure to the relay, add 10 PSI to the calculated theoretical gas supply pressure.

Example: *The LINC84T-13-x4 is capable of pumping up to a maximum of 9,000 psig. The Amplification Ratio for this pump is 60:1. Assume that we are going to be pumping into a system that is at 6,500 psig. Then 6,500 divided by 60 equals 108 psig; add 10 psig to the 108 psig which equals 118 psig as your result. Set the regulator that feeds the relay at 118 psig.*

The supply pressure to the timer of the 84T should be set high enough to make the relay stroke reliably. The timer supply pressure must be equal to or slightly lower than the relay supply pressure..

METERING PUMPS

P N E U M A T I C P L U N G E R

Figure 1, LINC 84T-13 Series Pump

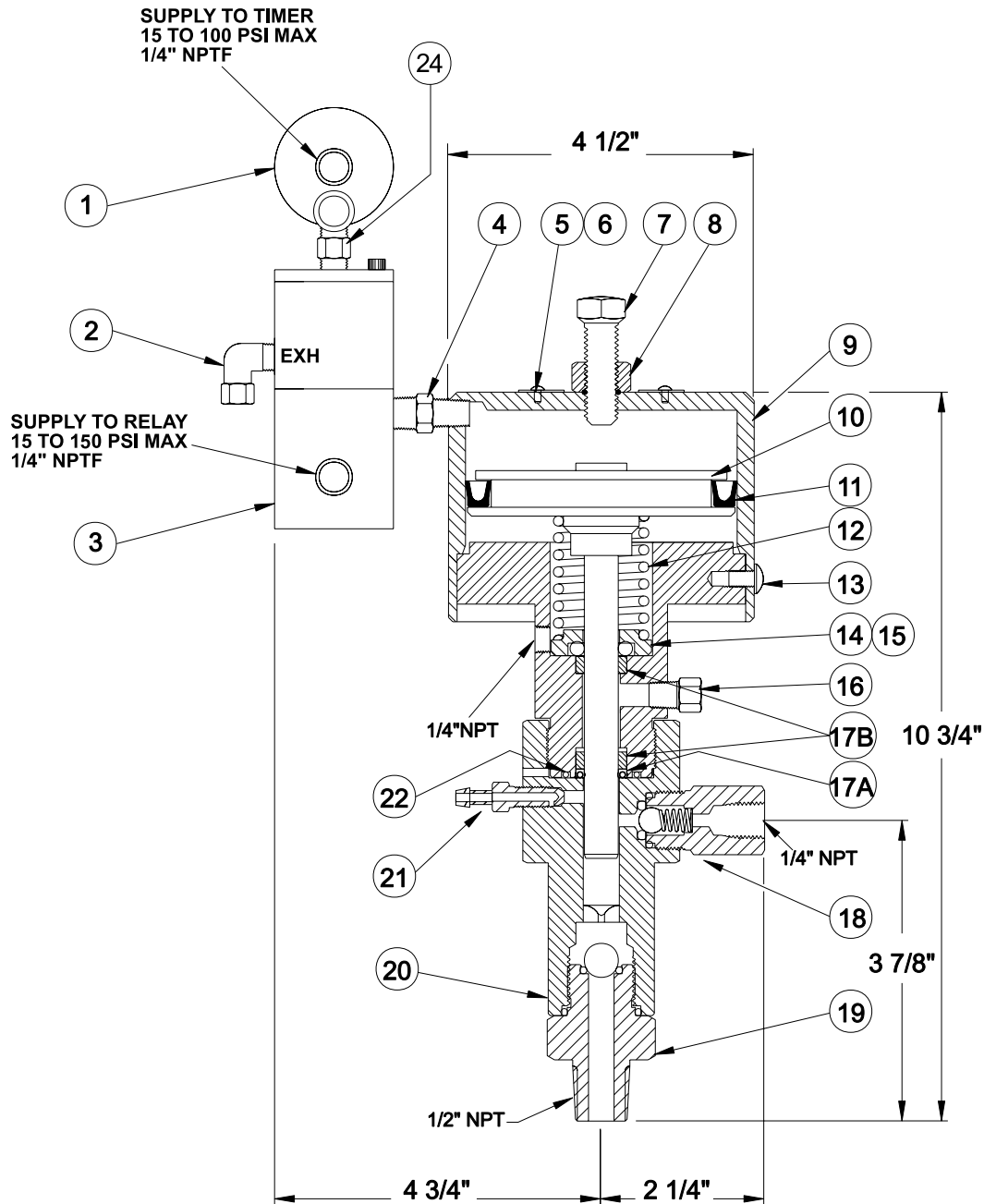

MODEL 84T-13-X4

METERING PUMPS

P N E U M A T I C P L U N G E R

LINC84T-13 Series Parts List

Model	84T-13-x4			
Plunger Size	1/2"			
Piston Size	4"			
Item	Part#	Description	Material	Qty
1	31668	Pneumatic Timer	303 ss	1
2	23339	Vent Assembly	Plated	1
3	31685	Pneumatic Relay	303 ss	1
4	11819	Nipple	316 ss	1
5	10289	Nameplate	18-8 ss	1
6	10324	Nameplate Drive Screw	18-8 ss	2
7	11843	Stroke Adjustment Screw	18-8 ss	1
8	20985	Sealing Jam Nut	18-8 ss	1
9	31127	Piston Housing	303 ss	1
10	31513	Piston Assembly	17-7 ss	1
11	11586	Piston U-Cup	Nitrile	1
12	12992	Plunger Return Spring	17-7 ss	1
13	11753	Piston Housing Screw	18-8 ss	6
14	24713	Lubricant Seal Retainer	Acetal	1
15	12991	Lubricant Seal	Fluorocarbon	1
16	10278	Lubricant Plug 1/8" NPT	304 ss	1
17	See Page 11	Plunger Seal Assembly		
18	See Page 14	Discharge Check Valve Assembly	316 ss	
19	See Page 15	Suction Check Valve Assembly	316 ss	
20	31511	Pump Body Assembly	316 ss	1
21	20460	Bleed Screw	316 ss	1
22	10466	O-Ring	Fluorocarbon	1
23	12990	Split Bushing	Filled PTFE	1
24	25130	Hexnipple	30355	1

METERING PUMPS

P N E U M A T I C P L U N G E R

LINC84T-13 Series Seal Materials

Model 84T-13-14

Item	Description	Part #	Material	Qty
17A	Plunger Seal	10525	Fluorocarbon	1
17B	Back Up	25374	Peek	1
18	Discharge Check Assembly	22624	See Parts	1
19	Suction Check Assembly	24779	See Parts	1

Model 84T-13-24

Item	Description	Part #	Material	Qty
17A	Plunger Seal	21196	Fluoromyte	1
17B	Back Up	25374	Peek	1
18	Discharge Check Assembly	22626	See Parts	1
19	Suction Check Assembly	24778	See Parts	1

Model 84T-13-34

Item	Description	Part #	Material	Qty
17A	Plunger Seal	10526	Nitrile	1
17B	Back Up	25374	Peek	1
18	Discharge Check Assembly	22625	See Parts	1
19	Suction Check Assembly	24780	See Parts	1

Model 84T-13-44

Item	Description	Part #	Material	Qty
17A	Plunger Seal	11004	TFE/Graphite	1
17B	Back Up	25374	Peek	1
18	Discharge Check Assembly	22626	See Parts	1
19	Suction Check Assembly	24778	See Parts	1

Model 84T-13-64

Item	Description	Part #	Material	Qty
17A	Plunger Seal	12963	UHMWPE	1
17B	Back Up	25374	Peek	1
18	Discharge Check Assembly	22626	See Parts	1
19	Suction Check Assembly	24778	See Parts	1

METERING PUMPS

P N E U M A T I C P L U N G E R

Figure 2, Timer

Reference fig. 1, item 1

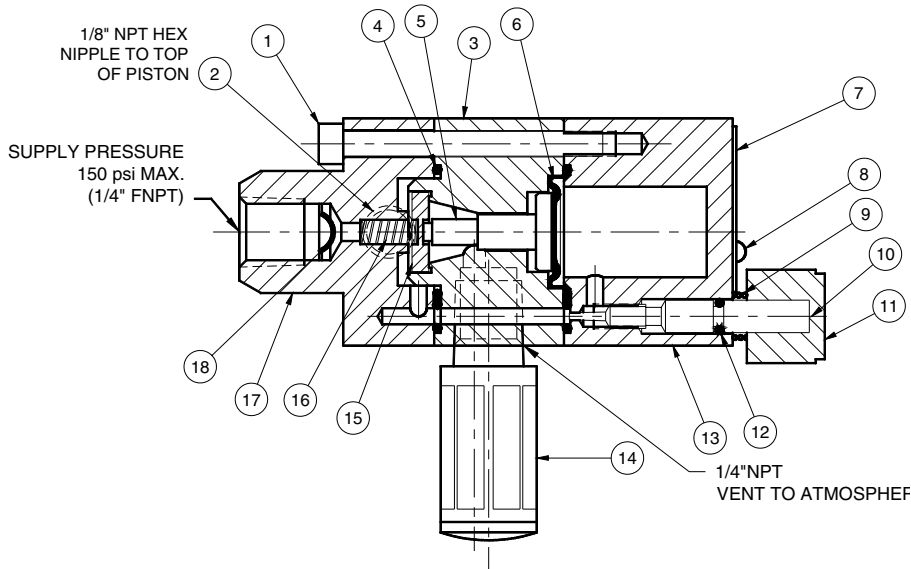

Assembly Item	31668 Part #	Timer Description	Material	Qty
1	13223	Screw	18-8 ss	2
2	25130	Hex Nipple	303 ss	1
3	31664	Center Body	303 ss	1
4	13227	Seal	Nitrile	1
5	13247	Disc Actuator	Delrin	1
6*	13226	Diaphragm	Nitrile	1
7	13246	Nameplate	18-8 ss	1
8	10324	Drive Screw	18-8 ss	2
9	13253	Knob Spring	Stainless steel	1
10	25149	Adjustment Screw	303 ss	1
11	13243	Knob	Polycarbon	1
12	10326	O-ring	Nitrile	1
13*	31663	Front Body	303 ss	1
14	12952	Muffer		1
15	13225	Disc	Aluminum/Nitrile	1
16*	13222	Disc Spring	Stainless steel	1
17	31665	Rear Body	303 ss	1
18*	10244	Screen	Stainless steel	1
*	25183	Repair Kit		1

METERING PUMPS

P N E U M A T I C P L U N G E R

Figure 3, Single Acting Relay

Reference fig. 1, item 3

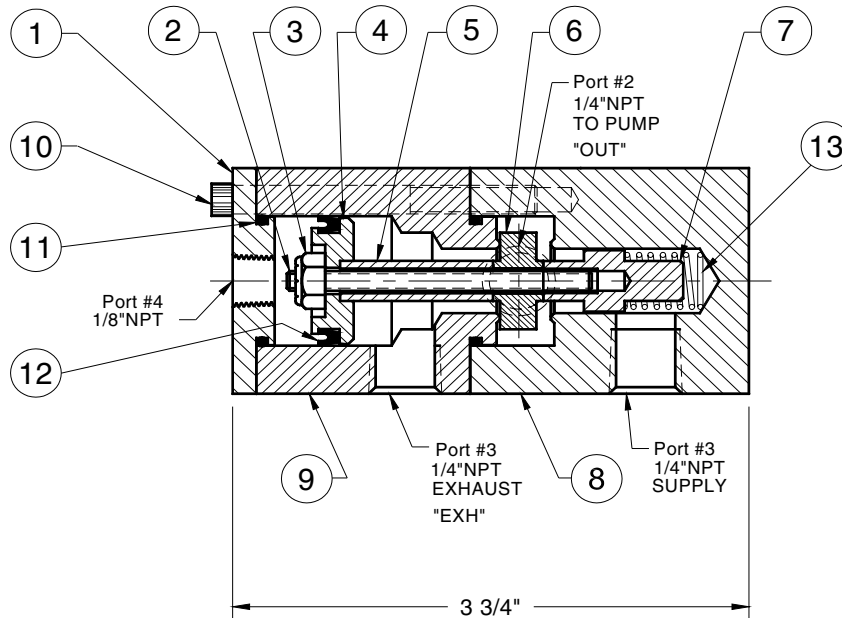

Assembly Item	31685 Part #	Single Acting Relay Assembly Description	Material	Qty
1	25003	Lid	303 ss	1
2	25112	Threaded Rod	316 ss	1
3	13078	Lock Nut	18-8 ss	1
4	24828	Piston	316 ss	1
5	24827	Piston Spacer	316 ss	1
6	24746	Seal Poppet	316 ss/Nitrile	1
7	24923	Spring Shaft	316 ss	1
8	31687	Lower Body	303 ss	1
9	31643	Upper Body	303 ss	1
10	10193	Cap Screw	18-8 ss	4
11	12364	O-Ring	Nitrile	2
12	12365	Piston Seal	Nitrile	1
13	13036	Spring	Stainless steel	1
*	25182	Repair Kit		1

METERING PUMPS

P N E U M A T I C P L U N G E R

Figure 4, Discharge Check Valve
Reference fig. 1, item 18

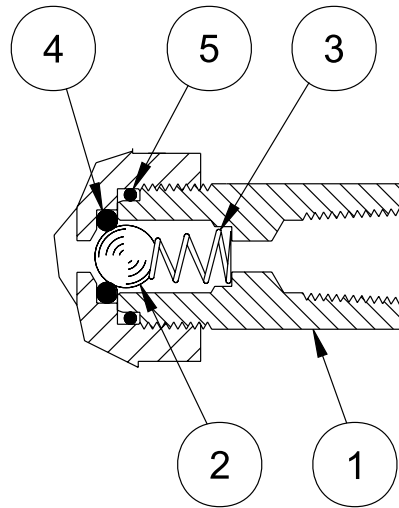

Assembly	22624	22525	22626	Discharge Check Valve One Piece Body	Port Size 1/4" NPTF	
Item	Part #	Part #	Part #	Description	Material	Qty
1	20570	20570	20570	Body	316 ss	1
2	10283	10283	10283	Ball	Carbide	1
3	10068	10068	10068	Spring	316 ss	1
4	10312			Seat	Fluorocarbon	1
		10328		Seat	Nitrile	1
			10317	Seat	TFE	1
5	10482			Seal	Fluorocarbon	1
		10124		Seal	Nitrile	1
			10481	Seal	TFE	1

METERING PUMPS

P N E U M A T I C P L U N G E R

Figure 5, Suction Check Valve

Reference fig. 1, item 19

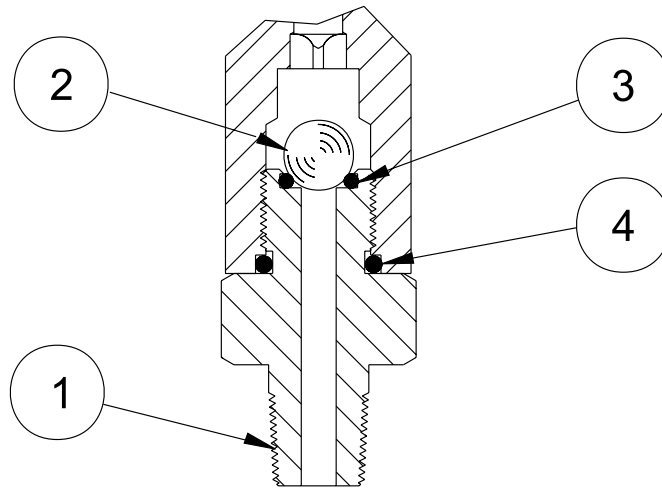

Suction Check Valves - One Piece Body

Part Number 24778

Port Size 1/2" NPTM

Item	Description	Part #	Material	Qty
1	Inlet Body	24787	316 ss	1
2	Ball	10529	Carbide	1
3	Seat	10469	TFE	1
4	Seal	10467	TFE	1

Part Number 24779

Port Size 1/2" NPTM

Item	Description	Part #	Material	Qty
1	Inlet Body	24787	316 ss	1
2	Ball	10529	Carbide	1
3	Seat	10337	Fluorocarbon	1
4	Seal	10466	Fluorocarbon	1

Part Number 24780

Port Size 1/2" NPTM

Item	Description	Part #	Material	Qty
1	Inlet Body	24787	316 ss	1
2	Ball	10529	Carbide	2
3	Seat	10121	Nitrile	1
4	Seal	10468	Nitrile	1

METERING PUMPS

LINC Chemical Pump Gas Consumption Table

ACTUATION PISTON DIA. (IN)>>	1.50	2.25	3	4	4	4	6	8	10
>> CONFIGURATION >>	SPRING RETURN NO RELAY	SPRING RETURN NO RELAY	SPRING RETURN NO RELAY	SPRING RETURN NO RELAY	SPRING RETURN INCLUDING RELAY	GAS RETURN INCLUDING RELAY	GAS RETURN INCLUDING RELAY	GAS RETURN INCLUDING RELAY	GAS RETURN INCLUDING RELAY
SUPPLY PRESS. (PSI)	VOLUME DISPLACED BY PISTON FOR 1" STROKE(CUBIC FEET)								
	0.00102265	0.00230097	0.00409062	0.00727221	0.00727221	0.01454441	0.03272492	0.05817764	0.09090257
	THEORETICAL GAS CONSUMPTION FOR EACH 1" STROKE (SCF)								
0	0.0000	0.0000	0.0000	0.0000	0.0000	0.0000	0.0000	0.0000	0.0000
10	0.0017	0.0039	0.0069	0.0122	0.0122	0.0244	0.0550	0.0978	0.1527
20	0.0024	0.0054	0.0097	0.0172	0.0172	0.0343	0.0772	0.1373	0.2146
30	0.0031	0.0070	0.0124	0.0221	0.0221	0.0442	0.0995	0.1769	0.2764
40	0.0038	0.0086	0.0152	0.0271	0.0271	0.0541	0.1218	0.2165	0.3383
50	0.0045	0.0101	0.0180	0.0320	0.0320	0.0640	0.1440	0.2561	0.4001
60	0.0052	0.0117	0.0208	0.0370	0.0370	0.0739	0.1663	0.2956	0.4619
70	0.0059	0.0133	0.0236	0.0419	0.0419	0.0838	0.1886	0.3352	0.5238
80	0.0066	0.0148	0.0264	0.0468	0.0468	0.0937	0.2108	0.3748	0.5856
90	0.0073	0.0164	0.0291	0.0518	0.0518	0.1036	0.2331	0.4144	0.6474
100	0.0080	0.0180	0.0319	0.0567	0.0567	0.1135	0.2553	0.4539	0.7093
110	0.0087	0.0195	0.0347	0.0617	0.0617	0.1234	0.2776	0.4935	0.7711
120	0.0094	0.0211	0.0375	0.0666	0.0666	0.1333	0.2999	0.5331	0.8330
130	0.0101	0.0226	0.0403	0.0716	0.0716	0.1432	0.3221	0.5727	0.8948
140	0.0108	0.0242	0.0430	0.0765	0.0765	0.1531	0.3444	0.6123	0.9566
150	0.0115	0.0258	0.0458	0.0815	0.0815	0.1630	0.3667	0.6518	1.0185