

# **PULSAFEEDER**<sup>®</sup>

A Unit of IDEX Corporation

---

## **PULSAR**<sup>®</sup>

HYDRAULIC DIAPHRAGM METERING PUMPS

### Installation, Operation & Maintenance Instruction

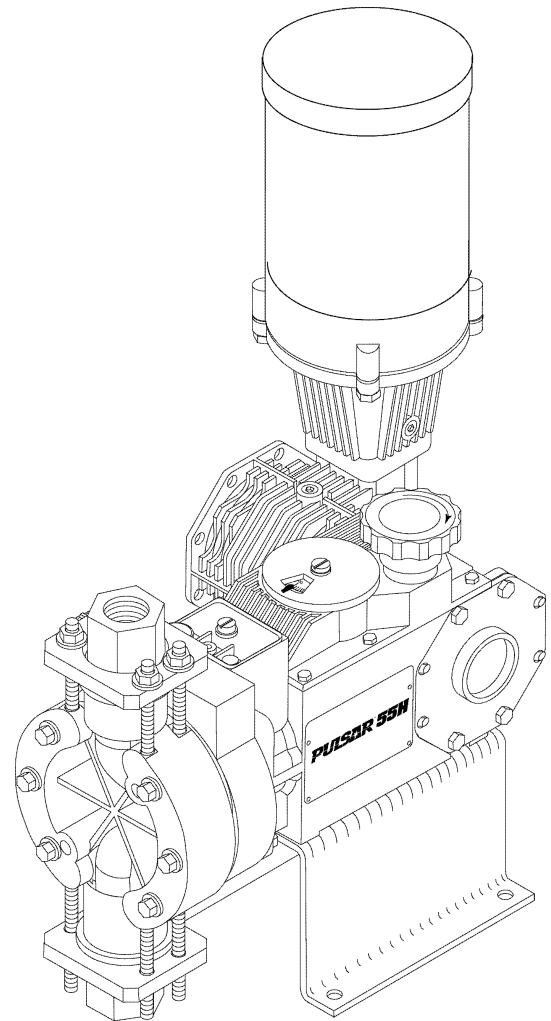

**Bulletin #: PR – IOM – 0802 - D**

---

 **PULSAFEEDER**  
A Unit of IDEX Corporation

Manufacturers of Quality Pumps,  
Controls and Systems

ENGINEERED PUMP OPERATIONS  
2883 Brighton Henrietta Townline Road  
Rochester, New York, 14623  
Telephone (585) 292-8000 Fax (585) 424-5619  
[www.pulsa.com](http://www.pulsa.com) [pulsa@idexcorp.com](mailto:pulsa@idexcorp.com)



# PULSAR<sup>®</sup> Factory Service Policy

Should you experience a problem with your *PULSAR* pump, first consult the troubleshooting guide in your operation and maintenance manual. If the problem is not covered or cannot be solved, please contact your local Pulsafeeder Sales Representative, or our Technical Services Department for further assistance.

Trained technicians are available to diagnose your problem and arrange a solution. Solutions may include purchase of replacement parts or returning the unit to the factory for inspection and repair. All returns require a Return Authorization number to be issued by Pulsafeeder. Parts purchased to correct a warranty issue may be credited after an examination of original parts by Pulsafeeder. Warranty parts returned as defective which test good will be sent back freight collect. No credit will be issued on any replacement electronic parts.

Any modifications or out-of-warranty repairs will be subject to bench fees and costs associated with replacement parts.

## Safety Considerations:

1. Read and understand all related instructions and documentation before attempting to install or maintain this equipment
2. Observe all special instructions, notes, and cautions.
3. Act with care and exercise good common sense and judgment during all installation, adjustment, and maintenance procedures.
4. Ensure that all safety and work procedures and standards that are applicable to your company and facility are followed during the installation, maintenance, and operation of this equipment.

Copyright ©2003/2006 Pulsafeeder, Inc. All rights reserved.

Information in this document is subject to change without notice. No part of this publication may be reproduced, stored in a retrieval system or transmitted in any form or any means electronic or mechanical, including photocopying and recording for any purpose other than the purchaser's personal use without the written permission of Pulsafeeder, Inc.

# Table of Contents

1. INTRODUCTION .....	1
1.1 General Description .....	1
2. PRINCIPLES OF OPERATION.....	1
2.1 Overall Operation.....	1
2.2 Component Location and Operation.....	2
2.2.1 Reagent Head Assembly .....	2
2.2.2 PULSAlarm Leak Detection .....	3
2.2.3 Pump Head/Piston assembly .....	3
2.2.4 Control Assembly .....	4
3. EQUIPMENT INSPECTION.....	6
3.1 Storage Instructions .....	6
3.1.1 Short Term .....	6
3.1.2 Long Term.....	6
4. INSTALLATION .....	6
4.1 Location.....	6
4.2 Piping System .....	7
4.3 Suction Pressure Requirements .....	8
4.4 Discharge Pressure Requirements .....	8
4.5 Automatic Control (DLC, DLCM or MPC) .....	8
4.6 PULSAlarm Leak Detection Electrical Connections.....	9
5. EQUIPMENT SETUP .....	10
5.1 Lubrication .....	10
5.1.1 Oil Capacities.....	10
5.1.2 Gear Oil Fill .....	10
5.1.3 Hydraulic Oil Fill .....	11
5.2 PULSAlarm Leak Detection .....	11
Drive Motor Installation.....	12
5.2.1 Motor Rotation .....	12
5.2.2 Motor Installation.....	12
5.2.3 Electrical .....	12
6. STARTUP PROCEDURE .....	13
6.1 Output Adjustment.....	13
6.2 Suction System.....	14
6.3 Priming the Pumphead (Hydraulic System).....	14
6.4 Priming the Reagent Head (Product System).....	14
6.5 Calibration.....	15
6.6 Checking the Diagnostic Window .....	16
7. MAINTENANCE.....	17
7.1 Oil Changes.....	17
7.1.1 Gear Oil Change: .....	17
7.1.2 Hydraulic Oil Change:.....	18
7.2 Wet End Removal, Inspection, and Reinstallation.....	18
PULSAlarm Leak Detection System .....	18
7.2.1 Standard Diaphragm Replacement.....	19
7.2.2 Re-Priming the Pumphead .....	20
7.3 Check Valves.....	20
7.3.1 General Description.....	20
7.3.2 Removal, Inspection, and Reinstallation .....	20
7.4 Hydraulic Performance Valve (HPV).....	21

7.4.1	General Description.....	21
7.4.2	Check Valve Screen - Removal and Cleaning .....	21
7.4.3	HPV Removal and Replacement - A & B Pumphead Style.....	22
7.4.4	HPV Removal and Replacement - C & D Pumphead Style.....	23
7.5	Hydraulic Bypass Valve (HBV) .....	24
7.6	PTP (Push to Purge / Automatic Bleed Valve).....	25
7.6.1	General Description.....	25
7.6.2	Removal, Cleaning, & Reinstallation.....	25
7.7	Piston Seal .....	26
7.7.1	General Description.....	26
7.7.2	Removal .....	26
7.7.3	Reinstallation .....	26
7.8	Oil Seals .....	27
7.8.1	General Description.....	27
7.8.2	Removal and Replacement.....	27
7.9	Cover Assembly.....	28
7.9.1	Removal & Reinstallation .....	28
8.	PUMP MOTOR.....	29
8.1	Removal & Reinstallation .....	29
9.	REPLACEMENT PARTS.....	29
9.1	PULSAR KOPkit Program .....	29
9.2	Ordering KOPkits or Parts.....	29
10.	TROUBLESHOOTING CHART .....	30
10.1	Diagnosis of Diaphragm Failure.....	32
11.	APPENDIX I PULSALARM LEAK DETECTION SYSTEM .....	33
11.1	PULSAlarm Leak Detection Reagent Head Assembly.....	33
11.2	PULSAlarm Leak Detection Diaphragm .....	33
11.3	Leak Detection Option – Setup for Vacuum.....	34
11.4	Leak Detection Option – Setup for Pressure .....	34
11.5	Pressure System Set-up and Priming.....	35
11.6	Leak Detection System Maintenance .....	37
11.6.1	Vacuum Setpoint Adjustment .....	37
11.7	PULSAlarm Leak Detection Diaphragm Maintenance .....	38
11.7.1	Leak Detection Diaphragm Removal.....	38
11.7.2	Inspection .....	39
11.7.3	Leak Detection Diaphragm Reinstallation .....	39
11.8	Leak Detection system conversion .....	39
12.	APPENDIX II PIPING CALCULATIONS .....	40
	Suction Head Requirements .....	40
	System Back Pressure .....	42
	Nomenclature .....	42
13.	APPENDIX III OIL SPECIFICATIONS .....	43
	<i>PULSAlube # 7H</i> .....	43
	<i>PULSAlube # 8G</i> .....	43
14.	APPENDIX IV BOLT TORQUE RECOMMENDATIONS .....	44
15.	APPENDIX V PULSAFEEDER ACCESSORIES.....	44
	Pulsatrol Installation, Operation, & Removal Instructions .....	44
	Installation .....	45
	<i>PULSA</i> trol Removal.....	46
	Back Pressure Valve .....	46
	Pressure Relief Valve .....	46

## Conventions:

The following conventions are used in this document.



**A WARNING DEFINES A CONDITION THAT COULD CAUSE DAMAGE TO BOTH THE EQUIPMENT AND THE PERSONNEL OPERATING IT. PAY CLOSE ATTENTION TO ANY WARNING.**



**Notes are general information meant to make operating the equipment easier.**

## Revision History:

Rev D: Release 12-2006

- Added information on use of diagnostic window
- Added diaphragm failure information to troubleshooting section
- Revised oil level recommendations
- Added suction condition cautions
- General text and formatting corrections

# 1. Introduction

## 1.1 General Description

PULSAR metering pumps are positive displacement reciprocating pumps. They combine the high efficiency of the plunger pump with diaphragm sealing to prevent product leakage. Each pump consists of a power end and a process end separated by a hydraulically operated diaphragm. Individual pumps will vary in appearance due to various liquid ends, accessories, and multiplexing; however, the basic principles of operation remain the same.

## 2. Principles Of Operation

### 2.1 Overall Operation

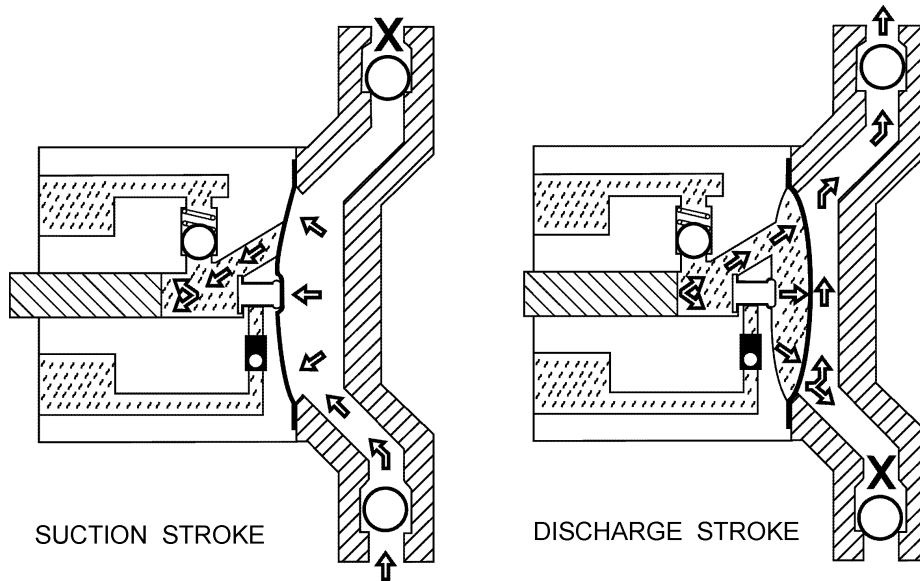

Figure 1

A piston reciprocates within an accurately sized cylinder at a preset stroke length, displacing an exact volume of fluid. This piston does not pump chemicals: it pumps hydraulic oil. The piston and associated mechanisms are enclosed in the eccentric box that also serves as a hydraulic oil reservoir. A diaphragm separates the oil from the product pumped. The diaphragm moves in exact response to piston displacement. The diaphragm does no work, and acts only as a separator. Consequently, oil displacement is translated into equal product displacement. Piston retraction causes the product to enter through the suction check valve. Piston advance causes the discharge of an equal amount of the product through the discharge check valve.

## 2.2 Component Location and Operation

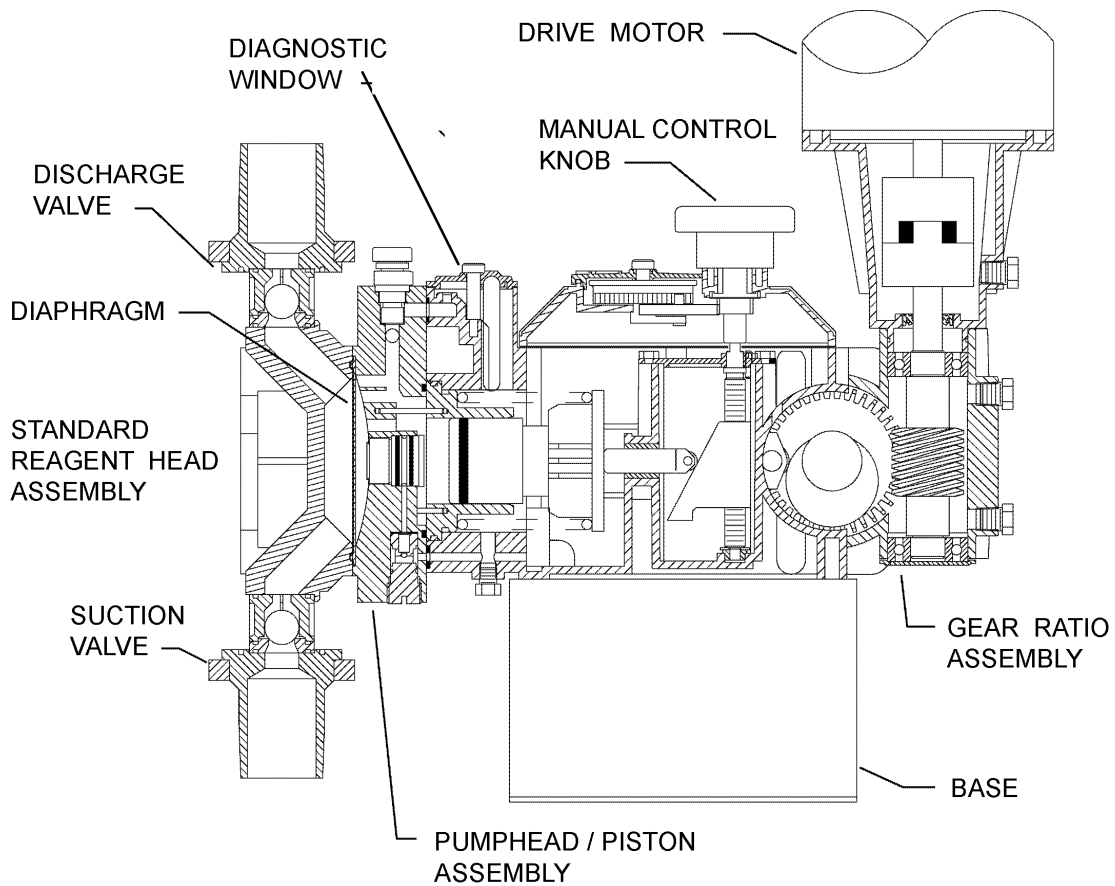

Figure 2

### 2.2.1 Reagent Head Assembly

The typical reagent head assembly consists of reagent head, diaphragm, and suction and discharge check valves. This assembly is the only part of the pump to contact the process liquid; consequently, maintenance is critical to pump performance.

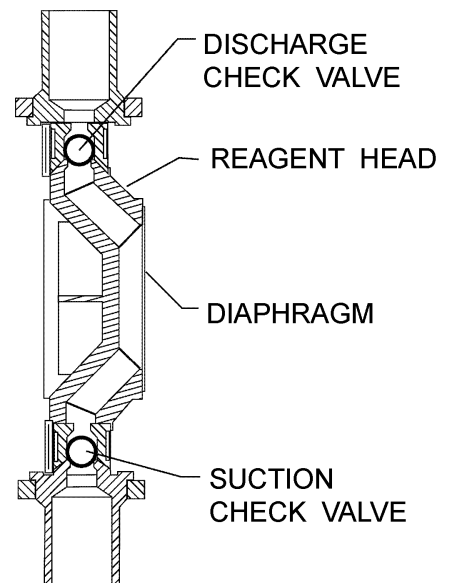

Figure 3

## 2.2.2 PULSAlarm Leak Detection

The PULSAlarm leak detection reagent head assembly consists of reagent head, leak detection diaphragm, suction and discharge check valves, vacuum bleed port, and optional pressure switch and gauge. If your pump is equipped with this option, refer to *Appendix I* on page 33 for further information.



**A sealed system must be maintained at all times during pump operation, whether leak detection is required or not. If the proper level of vacuum, between 10 in and 26 in. (250mm to 650mm) Hg, or a sealed pressure system is not present, decreased flow and/or diaphragm damage will occur. Please note that the factory setpoint for actuation of the vacuum switch is 6 in (152mm) Hg (vacuum) or 5 psig (pressure).**

## 2.2.3 Pump Head/Piston assembly

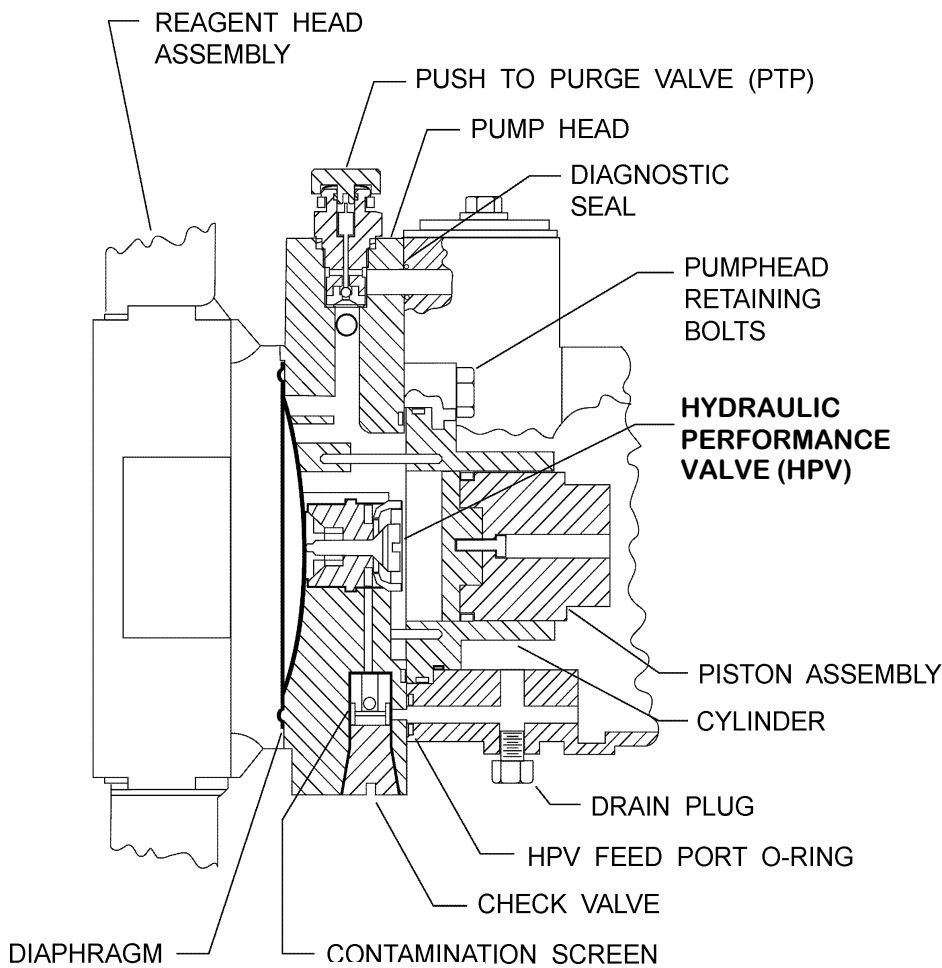

Figure 4

The pump head/piston assembly is installed on the eccentric box. This assembly contains the hydraulic system consisting of the pump head, cylinder, piston assembly, and three hydraulic valves:

**PTP (Push-To-Purge)**  
**HPV (Hydraulic Performance Valve)**  
**HBV (Hydraulic Bypass Valve).**

The **PTP** valve is situated at the top of the pump head and automatically removes gases from the hydraulic system during normal operation. Momentary manual actuation of the external valve button overrides automatic operation to validate priming or to determine diaphragm integrity.

The **HPV** automatically maintains the required hydraulic oil volume by replacing any oil lost past the piston or through the PTP valve.

The **HBV** protects the pump from over-pressurizing by relieving any excess pressure in the pump's hydraulic system.

## 2.2.4 Control Assembly

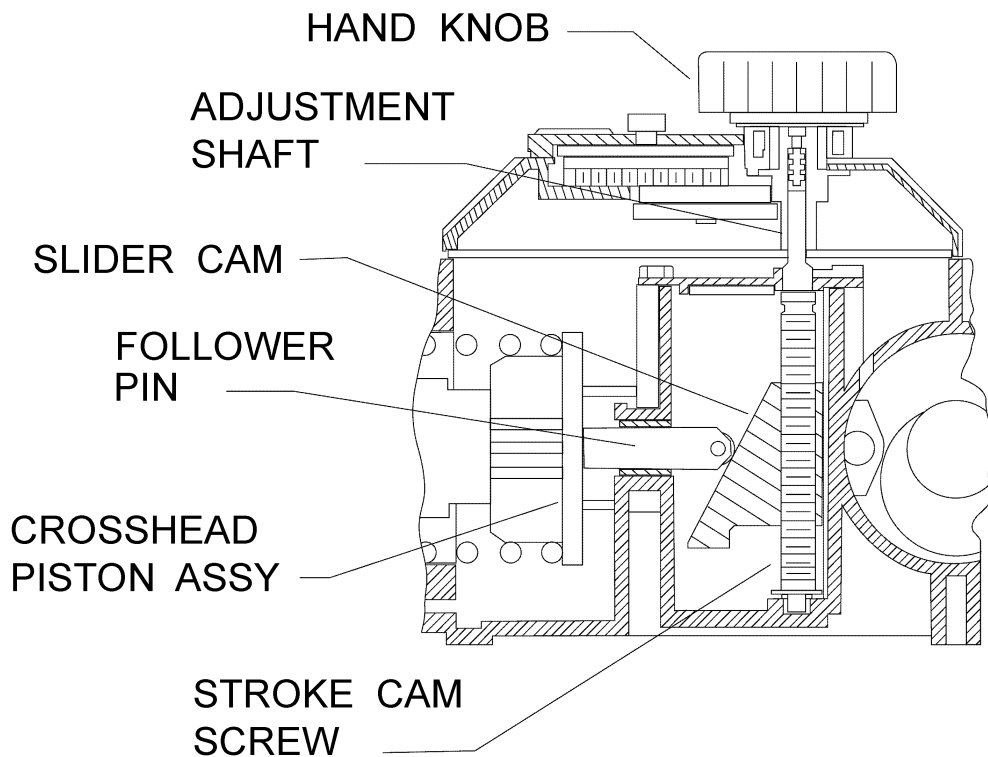

Figure 5

PULSAR pumps incorporate a lost motion style of stroke length adjustment to limit piston travel during the suction portion of each stroke. The stroke length setting is denoted by a (0 - 100) scale located on the top of the unit.

Stroke is changed by depressing and turning the hand knob. This turns a screw which locates a slider cam to position the follower pin as to limit the rearward travel of the piston. If the control cover is removed and replaced, the bolts should be tightened to 20-24 In-lb (225 – 270 N-cm).

PULSAR pumps may also be equipped with the Pulsafeeder DLC or DLCM electronic stroke length controllers. These allow for local and/or remote automatic control over stroke length (DLC) or stroke length and motor speed (DLCM). Pumps equipped with the DLC or DLCM controllers are provided with separate instructions for the controller. Refer to the appropriate Installation, Operation and Maintenance Manual (IOM-PS-DLC-1101 or IOM-PS-DLCM-1101).

Some PULSAR pumps may also be equipped with the MPC control which allows for pump flow control over a wide range via a specially designed variable speed drive. The MPC Installation, Operation and Maintenance manual IOM-MPC-0104 covers information specific to this type of control and should be consulted prior to operating the pump or the controller.

## 2.2.5 Gear Ratio Assembly

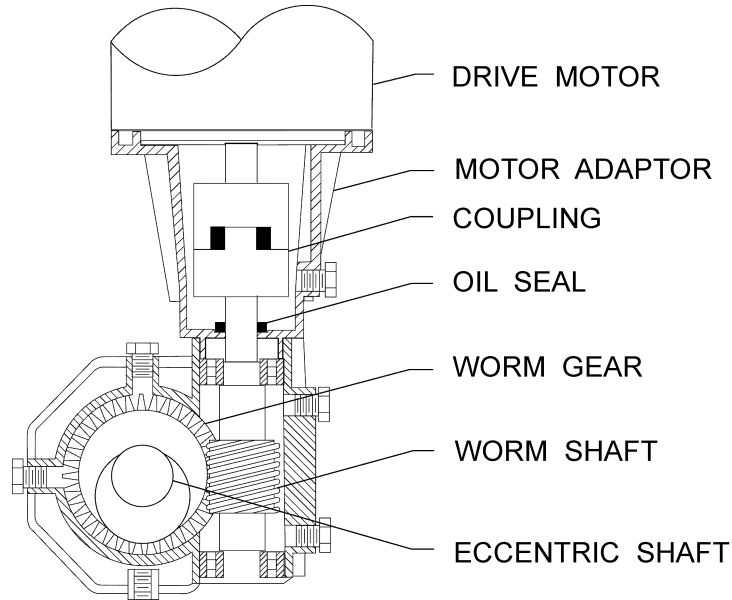
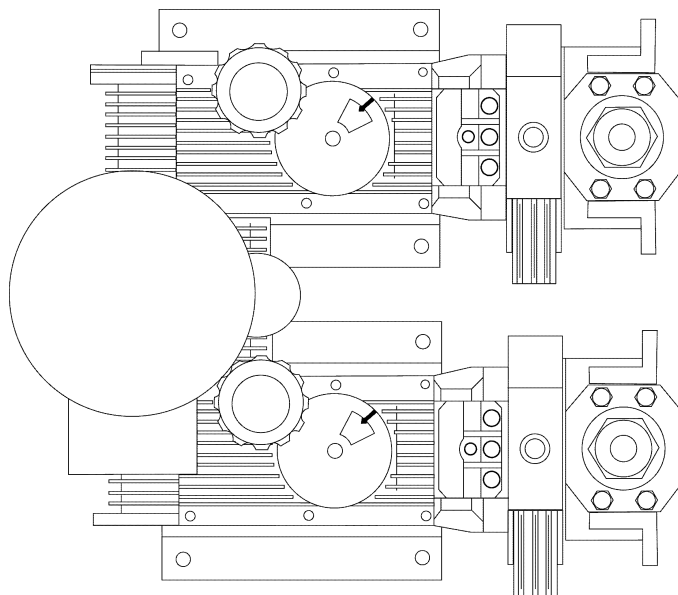

Figure 6

PULSAR pumps are driven by a standard C-face electric motor mounted on the motor adaptor input flange. The motor drives a set of worm gears which convert rotational speed into torque. They in turn power the eccentric shaft assembly that converts rotary motion to reciprocating motion. The motor adaptor is available in a variety of configurations to accommodate different motor frame specifications.



More than one pump can be driven through a single drive assembly. This is referred to as multiplexing. The pumps are mounted on a common gear reducer assembly on the driver pump and the pump without a gear reducer is called the driven pump. Each pump is mounted on its respective standard simplex base.

Whenever pumps are multiplexed, the eccentric shafts are positioned to place a uniform load on the driver. Before full disassembly always note the relative positions of the eccentric shafts to each other so they can be reassembled in the same orientation.

Figure 7

## 3. Equipment Inspection

Check all equipment for completeness against the order and for any evidence of shipping damage. Shortages or damage should be reported immediately to the carrier and your Pulsafeeder representative.

### 3.1 Storage Instructions

#### 3.1.1 Short Term

Storage of PULSAR pumps for up to 12 months is considered short-term. The recommended short-term storage procedures are:

- a) Store the pump indoors at room temperature in a dry environment.
- b) Within two months after date of shipment, fill the eccentric box to its normal operating level with *PULSAlube 7H* (purple) hydraulic oil. If required by the operating environment, take steps to prevent entry of water or humid air into the eccentric enclosure.
- c) Prior to start up, inspect housing, and gearbox. Replenish hydraulic and gearbox oils as required to maintain operating levels. If water or condensation is present, change oil as described under Equipment Startup.
- d) Start up in accordance with instructions in this manual.

#### 3.1.2 Long Term

Every twelve months, in addition to the above short-term procedures, power up the motor and operate the pump for a minimum of one hour. It is not necessary to have liquid in the reagent head during this operation, but the suction and discharge ports must be open to atmosphere. If the pump is equipped with a PULSAlarm vacuum leak detection system, ensure that a vacuum is drawn before operating the pump. See *Appendix I* on page 33 for more information.

After twelve months of storage, Pulsafeeder's warranty cannot cover such items which are subject to deterioration with age such as seals and gaskets. If the pump has been in storage longer than 12 months it is recommended that such items be inspected and replaced as necessary prior to startup. Materials and labor to replace this class of item under this circumstance are the purchaser's responsibility. For a continuance of the warranty after extended storage, equipment inspection and any required refurbishing must be done by a Pulsafeeder representative.

## 4. Installation

### 4.1 Location

When selecting an installation site or designing a skid package, consideration should be given to access for routine maintenance.

PULSAR pumps are designed to operate indoors and outdoors, but it is desirable to provide a hood or covering for outdoor service. External heating may be required if ambient temperatures below  $-18^{\circ}\text{C}$  ( $0^{\circ}\text{F}$ ) are anticipated. Check with the factory regarding suitability of the operating environment.

The pump must be rigidly bolted to a solid and flat foundation to minimize vibration, which can loosen connections. When the pump is bolted down, care must be taken to avoid distorting the base and affecting alignments. The pump must be level within  $2^{\circ}$ . This will assure that the hydraulic and gear oils are maintained at the proper levels and that the check valves can operate properly.

## 4.2 Piping System

All piping systems should include:

1. Shutoff valves and unions (or flanges) on suction and discharge piping. This permits check valve inspection without draining long runs of piping. Shutoff valves should be of the same size as connecting pipe. Ball valves are preferred since they offer minimum flow restriction.
2. An inlet strainer, if the product is not a slurry. Pump check valves are susceptible to dirt and other solid contaminants unless designed for that service, and any accumulation can cause a malfunction. The strainer should be located between the suction shutoff valve and the pump suction valve. It must be sized to accommodate the flow rate and the anticipated level of contamination. 100-mesh screen is recommended.
3. Vacuum/pressure gauges in the suction and discharge lines in order to check system operation. Gauges should be fitted with protective shutoff valves for isolation while not in use.
4. A separate system relief valve to protect piping and process equipment, including the pump, from excess process pressures.

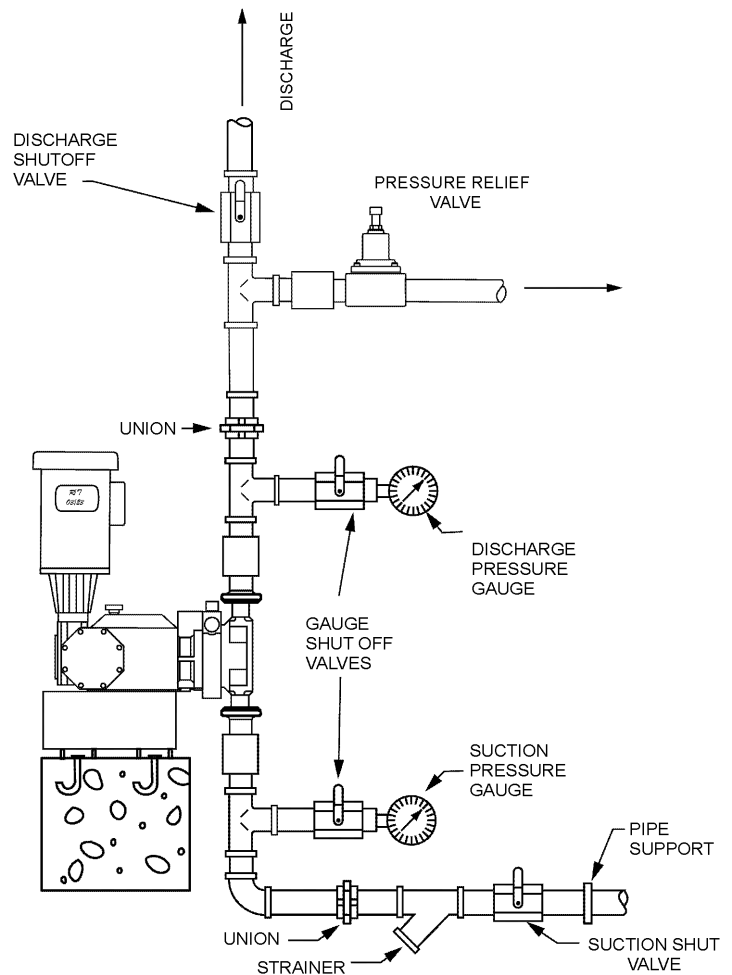

Figure 8



**The hydraulic bypass valve (HBV) in the pump is not intended to protect the system!**

Piping weight must not be supported by the valve housings or other portions of the reagent head, as the resulting stresses can cause leaks. If appropriate, provide for thermal expansion and contraction so that no excess force or moments are applied to the pump.

In piping assembly, use a sealing compound chemically compatible with the process material.

Users of sealing tape are cautioned to ensure that the pipe thread ends are not taped. Both new and existing piping should be cleaned, preferably by flushing with a clean liquid (compatible with process material) and blown out with air, prior to connection to the pump. Flow issues at pump startup are often related to the check valves being fouled with piping and process debris.

## 4.3 Suction Pressure Requirements

Although PULSAR metering pumps have suction lift capability, all pump installations should have minimum lift for optimum performance. A flooded suction (i.e., suction pressure higher than atmospheric pressure) is preferable whenever possible. The pump should be located as close as possible to the suction side reservoir or other source. Piping should be sized to allow for best possible NPSH conditions.



**It is not recommended to install a PULSAlarm equipped pump in a suction lift system.**

If suction lift is required, the net positive suction pressure required (NPSHr) is 0.21 bar (or 3 psia). If this requirement is not met the process liquid may cavitate inside the pump, degrading metering accuracy. To maintain prime on a suction installation, a foot valve is required. In addition, suction pressure must be maintained at a minimum absolute value of 0.35 bar (or 5 psia) to ensure proper hydraulic system and proper pump operation.

The maximum inlet pressure is limited to 30 psig with the standard composite diaphragm. Higher suction pressures may be accommodated with optional diaphragm configurations.



**It is critical that PULSAR pumps have free flowing and unobstructed suction conditions at all times. Closed valves, clogged strainers, obstructed piping, etc, are to be avoided. Suction restrictions can place stress on the diaphragm that may result in premature failure.**

Refer to *Appendix II* for procedures for the calculation of suction pressure.

## 4.4 Discharge Pressure Requirements

All PULSAR Metering Pumps are designed for continuous service at the rated discharge pressure. If system suction pressure were to exceed system discharge pressure (a condition sometimes described as “pumping downhill”), flow would be generated in addition to that caused by the pump, resulting in a reduction in accuracy and loss of control over the metering process. To prevent this condition, commonly referred to as “flow-through”, discharge pressure must exceed suction pressure by at least 0.35 Bar (or 5 psi). This can be achieved where necessary by the installation of a backpressure valve in the discharge line.

Discharge systems should be protected from excessive pressures by utilizing a pressure relief or pressure limiting valve in the piping system. Operation of the pump at pressure above its nameplate rated maximum may result in damage to the pump components and/or unsafe system conditions.

Refer to *Appendix II* for procedures for the calculation of discharge pressure.

## 4.5 Automatic Control (DLC, DLCM or MPC)

Pumps equipped with the electronic controllers are provided with separate instructions. Refer to DLC manual IOM-PS-DLC-1101, DLCM manual IOM-PS-DLCM-1101, or MPC manual IOM-MPC-0104. Perform all DLC, DLCM or MPC installation procedures prior to pump startup.

## 4.6 PULSAlarm Leak Detection Electrical Connections

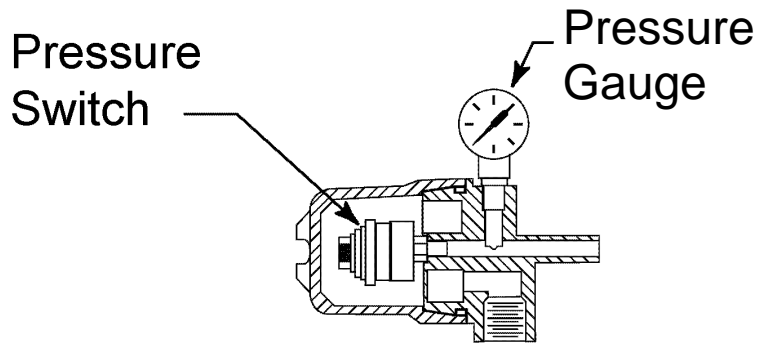

### Pressure Switch Enclosure

Figure 9

If equipped with an optional vacuum or pressure switch, install electrical wiring and conduit in accordance with local electrical codes.

The switch is rated as follows:

**30 VDC or 125 VAC 1 Ampere Resistive.**

The switch is the SPDT (single pole, double throw) type and can therefore be connected to either open or to close upon detection of diaphragm leak condition. Contacts or wires are identified as follows:

<b>Normally Open (NO)</b>	<b>wire color WHITE</b>
<b>Normally Closed (NC)</b>	<b>wire color RED</b>
<b>Common (Com)</b>	<b>wire color BLACK</b>



**THE ENCLOSURE IS LABELED WITH APPLICABLE SAFETY AGENCY RATINGS FOR HAZARDOUS AREA INSTALLATION. SINCE THE SWITCH IS OF THE MECHANICAL CONTACT TYPE, IT CAN NEVER QUALIFY AS NON-SPARKING (NON-INCENDIVE, OR "M") FOR OCCASIONAL AND SHORT-TERM HAZARDOUS AREA USE. PROTECTION MUST BE PROVIDED BY THE ENCLOSURE.**

# 5. Equipment Setup

## 5.1 Lubrication



NOTE

PULSAR pumps use two separate oils: *PULSAlube 7H*, hydraulic oil for the eccentric box and *PULSAlube 8G*, gear oil for the gearbox. Confusion between the two will impair performance and damage the pump.



NOTE

PULSAR pumps are shipped from the factory with the Eccentric Housing drained, and the Gearbox full. The Installer should fill the Eccentric Housing. The external gearcase does not need to be checked.

### 5.1.1 Oil Capacities

*PULSAlube 7H* hydraulic oil is now available in 1 liter containers (previously 1.5 liters).

*PULSAlube 8G* gear oil is available in 200 ml containers.

It is recommended that adequate supplies of both *PULSAlube* oils be on hand for periodic changes and emergency requirements. The approximate amounts of oil required to fill PULSAR pumps to specified levels are:

Oil	Color	Application	Amount (approx.)
PULSAlube 7H	Purple	Eccentric Housing	1000 ml (1 quart) NP980002-005
PULSAlube 8G	Amber	P25H Series Gearbox	150 ml (0.16 quart)
		P55H Series Gearbox	200 ml (0.21 quart) NP980001-002

Please note that the eccentric box section of the pump is not completely full when the proper amount of oil is used, this is normal. Starting in production year 2007, Pulsafeeder will distribute *PULSAlube 7H* in 1 liter containers to facilitate proper oil fill.

### 5.1.2 Gear Oil Fill

In all pump configurations, one pipe plug is present at the top of the gearbox and one is on the side at the centerline level. Remove the top plug and fill with *PULSAlube 8G* (amber) gear oil through the top port to the level of the eccentric shaft centerline, which is level with the side port. If desired, the side plug can be removed so that leakage from the side port indicates attainment of the required level. Replace both pipe plugs after filling. Do not add oil through the port on the side of the motor adapter, as this port is for motor drive coupling access only.

### 5.1.3 Hydraulic Oil Fill

Remove the diagnostic window to gain access to the reservoir and add *PULSAlube 7H* hydraulic oil until the oil level is between the max and min as indicated on the new (flexible style) dipstick as illustrated below. For older pumps equipped with a solid dipstick, the oil level should be below the upper coils of the piston return spring, if the upper coils of the spring are submerged, the oil level is too high (ref. *Figure 10*). Adding 1 liter (approx. 1 quart) of oil to a fully drained pump will result in the correct fill level. High oil level will not affect the operation of the pump, however it can result in nuisance leakage of oil. Replace the window, making sure it is properly aligned and square before tightening the thumbscrew.

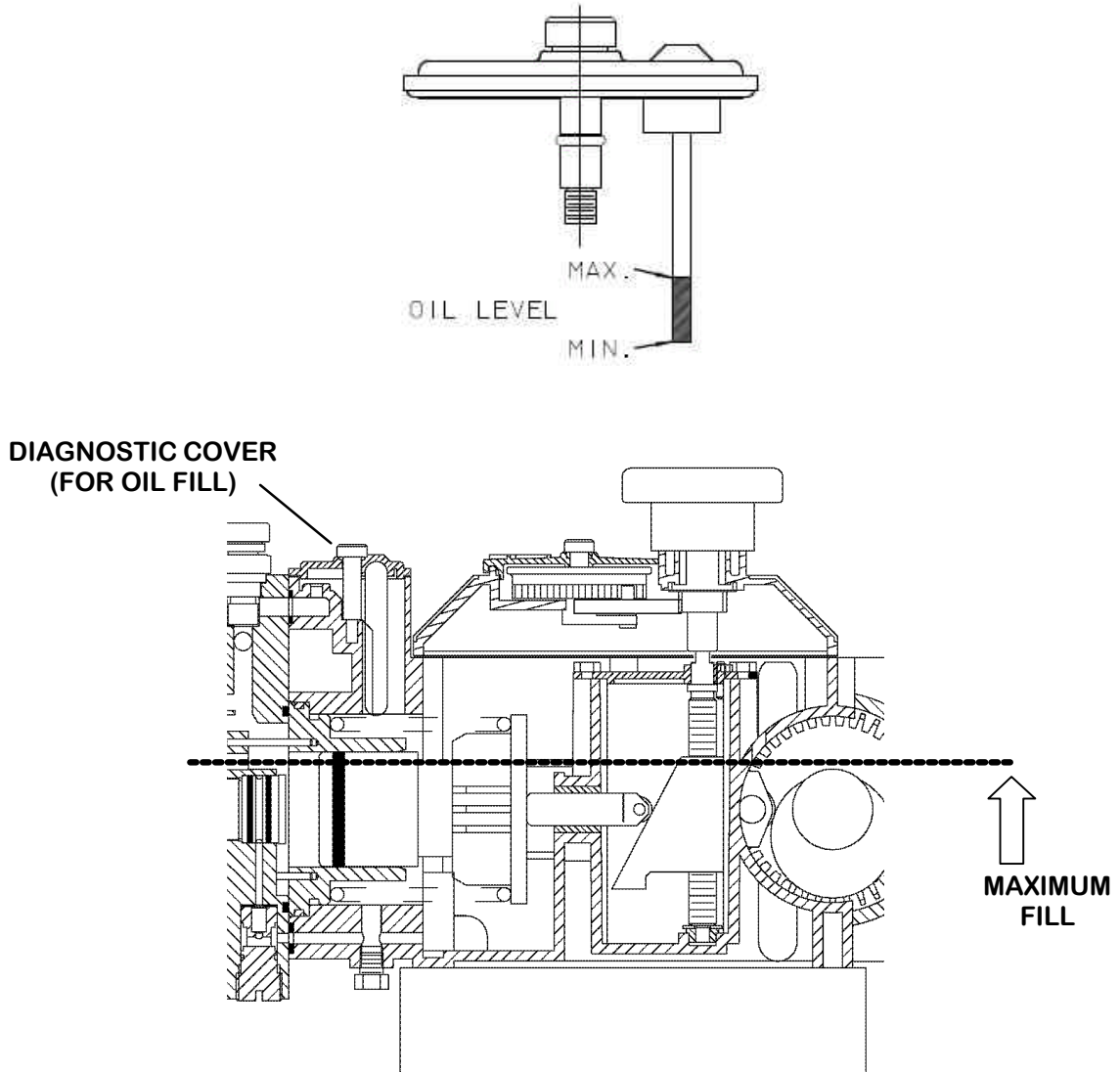

Figure 10

### 5.2 PULSAlarm Leak Detection



Refer to *Appendix I, page 33* for startup instructions specific to pumps equipped with the PULSAlarm diaphragm leak detection system

# Drive Motor Installation

## 5.2.1 Motor Rotation

Motor can be operated in either direction, clockwise or counterclockwise. Verification of motor direction is not necessary at startup.

## 5.2.2 Motor Installation

PULSAR pumps may be shipped with the drive motor packed separately. This is done to avoid damage during transport.

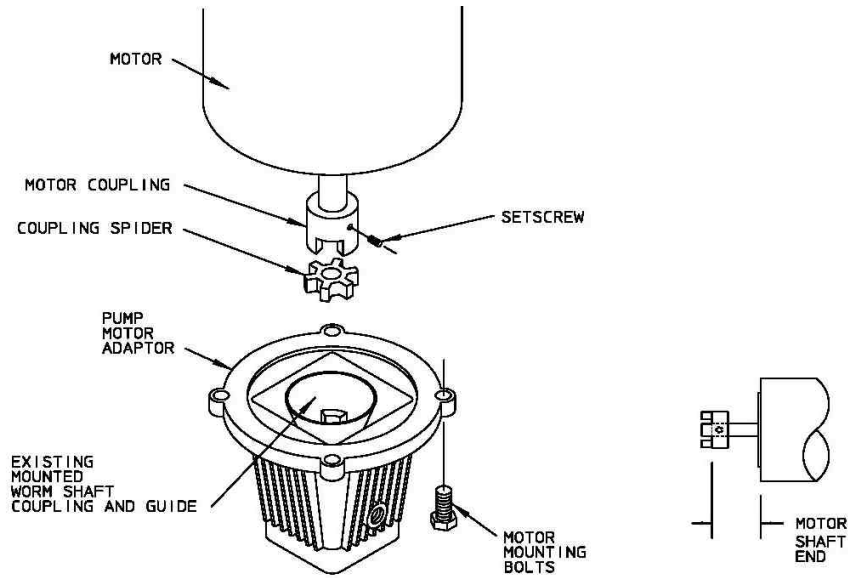

Figure 11

1. Remove the unattached coupling half from the motor adaptor. Ensure that the elastomer coupling spider remains in place, on the coupling half that remains attached to the worm shaft.
2. If applicable, remove any tape or retainer rings that hold the motor shaft key in place.
3. Place the loose coupling half on the motor shaft. Align the keyway with the key and align shaft end to inner coupling surface as shown in figure above.
4. Tighten the setscrew onto the shaft key.
5. Place the motor in a vertical position and align the coupling teeth.
6. Install the motor downwards onto the adaptor. The plastic guide will assist in aligning the coupling halves. Final position can be achieved by slightly rotating the motor until the coupling jaws align.
7. Rotate the motor until the clearance holes in the adaptor and the tapped holes in the motor align. Fasten the motor to the adaptor using the supplied bolts (4). Tighten bolts evenly to secure motor.

## 5.2.3 Electrical

Wire the PULSAR drive motor according to the motor vendor's nameplates and instructions, and according to any appropriate national and local electrical codes and regulations.

**If the motor is to be utilized with a Pulsafeeder controller, such as the DLC, DLCM, or MPC, consult the appropriate Pulsafeeder IOM for further motor wiring instructions.**

## 6. Startup Procedure

### 6.1 Output Adjustment

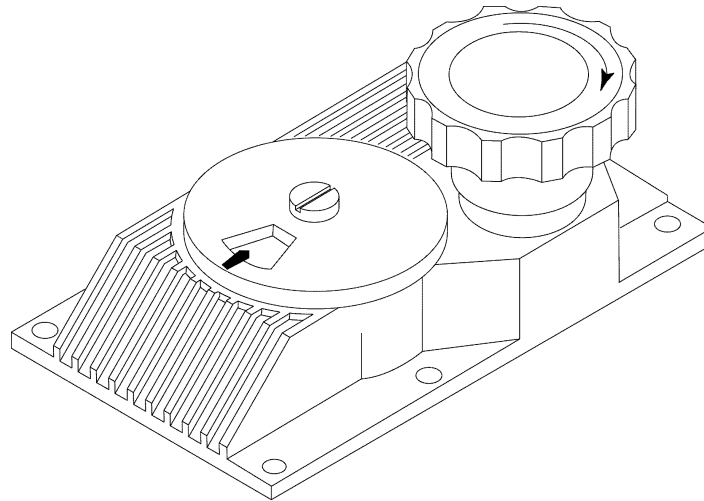

Figure 12

All PULSAR pumps have a hand-wheel for manual stroke length adjustment. Mounted atop the eccentric box, the hand-wheel can be adjusted at any point (from 0 to 100% stroke setting) by pressing down and then rotating the hand wheel as required. Stroke length is locked during operation to prevent drift: pressing the hand-wheel down temporarily disengages the lock for adjustment; release after adjustment automatically resets the lock at the new setting. An indicator adjacent to the hand-wheel displays the output setting. Adjustments can be made while the pump is at rest or operating, although operating adjustments are easier to make. Manual adjustment serves as a backup for pumps provided with an optional DLC stroke length controller. If the control cover is removed and replaced, the bolts should be tightened to 20-24 In-lb (225 – 270 N-cm).



**If the pump is equipped with a vacuum leak detection system, vacuum must be maintained at all times during pump operation, whether or not leak detection is required. If the proper level of vacuum (between 10 in and 26 in. (250mm to 650mm) Hg) is not present, decreased flow and/or diaphragm damage will occur. See *Appendix I* on page 33 for further information.**



**If the pump is equipped with a pressure leak detection system, the system must remain sealed at all times during pump operation, whether or not leak detection is required. If the seal is broken, decreased flow and/or diaphragm damage will occur. See *Appendix I* on page 33 for further information.**



**Leak Detection Diaphragm systems require special hydraulic priming considerations to protect the diaphragm from damage during initial pump startup. See *Appendix I* on page 33 for further information.**

## 6.2 Suction System

Before operation of any PULSAR pump, carefully ensure that all suction valves are in the open position. Verify that all filters and strainers are clean and clear. Ensure that any other potential causes of restriction have been addressed. Unrestricted flow of liquid to the suction side of the pump is critical to proper operation.

## 6.3 Priming the Pumphead (Hydraulic System)

All pumps are shipped with a fully primed hydraulic system. However, during shipping and handling some air may enter the hydraulic system. Generally this air will be automatically purged after a short run-in period. If necessary, rapid purging may be accomplished by fully depressing and holding the PTP valve while the pump is operating. With the valve depressed, oil should begin to flow out of the center diagnostic port. Continue to hold the valve down until the oil is clear of bubbles.

If the pump fails to prime, go to the next section and follow the Priming the Pumphead procedure (*Section 7.2.2*). See *Appendix I* on page 33 for further information if your pump is equipped with a PULSAlarm leak detection system.

## 6.4 Priming the Reagent Head (Product System)

1. Open the suction and discharge line shutoff valves.
2. If the piping system design and the storage tank are such that the product flows due to gravity through the pump, no priming is required. In the event the discharge line contains a significant amount of pressurized air or other gas, it may be necessary to lower the discharge pressure to enable the pump to self-prime.
3. If the installation involves a suction lift, it may be necessary to prime the reagent head and suction line. Try priming the reagent head first. Remove the discharge valve by unscrewing the four tie bar bolts and removing the valve as a unit. Fill the head through the discharge valve port with process (or compatible) liquid, then reinstall the valve and retighten the tie bar bolts.
4. Start the pump at the 0% stroke length setting and slowly increase the setting to 100% to prime the pump. If this does not work, it will be necessary to fill the suction line.
5. Filling of the suction line will necessitate the use of a foot valve or similar device at the end of the suction line so that liquid can be maintained above the reservoir level. Remove the suction valve assembly, fill the line, replace the valve, then remove the discharge valve assembly and fill the reagent head as described in Step (3) above. The pump will now self-prime when started up per step (4) above.

## 6.5 Calibration

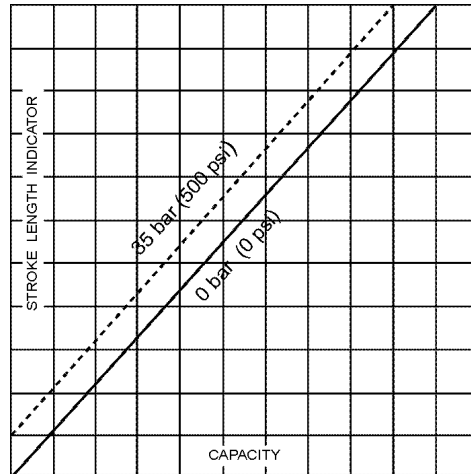

Figure 13

All metering pumps must be calibrated in order to accurately specify stroke length settings for required flow rates. For pumps provided with DLC or DLCM electronic stroke length control, refer to separate instructions as noted on page 8.

A typical calibration chart is shown in **Figure 13**. Although output is linear with respect to stroke length setting, an increase in discharge pressure decreases output uniformly, describing a series of parallel lines, one for each pressure (only two are shown).

The theoretical output flow rate at atmospheric output pressure is based on the displacement of the hydraulic piston (the product of piston cross-sectional area and stroke length) and the stroking rate of the pump. With increasing discharge pressure there is a corresponding decrease in output flow of approximately 1% per 7 bar (100 psig) increase in output pressure. Whenever possible, calibration should be performed under actual process conditions (i.e., the same or a similar process liquid at system operating pressure).

To assure a sound hydraulic system, run the pump for 10-15 minutes prior to calibration. This will allow the PTP (automatic bleed) valve to purge any air from the system.

To construct a calibration chart, measure the flow rate several times at three or more stroke settings (i.e., 25, 50, 75, and 100), plot these values on linear graph paper, and draw a best-fit line through the points. For stable conditions, this line should predict settings to attain required outputs.

Checking the actual flow rates is especially important in pumps producing low flow rates and operating against high discharge pressures. In this type of system, normal losses of efficiency can result in lack of measurable flow at shorter piston stroke lengths. This is a function of the system conditions and does not indicate a problem with the pump. Careful measurement of actual pump flow at several test points will allow for proper calibration over the complete flow range.

## 6.6 Checking the Diagnostic Window

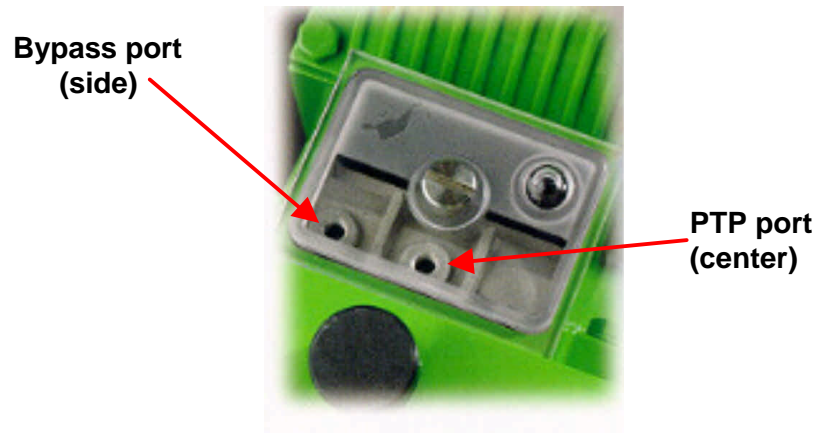

	<b>Bypass Port</b>	<b>PTP Port</b>
Connected to	The hydraulic bypass valve on the side of the pump head	The PTP push-button valve on the top of the pump head
Function	Bypass protects the pump from excessive pressure and hydraulic upset conditions	Allows any air trapped in the hydraulic system to escape
Normal operation	No oil should move through this port when the pump is operating normally	Small amount of oil will weep from port during operation, flow increases if PTP button is depressed
Abnormal operation	Oil is seen flowing from the port	No oil moving through the port at any time, or product (not oil) is seen
Things to check if abnormal operation is suspected	<ul style="list-style-type: none"> <li>○ Discharge pressure too high</li> <li>○ Bypass valve setpoint too low</li> <li>○ Bypass valve malfunction</li> <li>○ Other upset condition</li> </ul>	<ul style="list-style-type: none"> <li>○ PTP damaged</li> <li>○ HPV filter screen clogged</li> <li>○ HPV not operating properly</li> <li>○ Diaphragm damaged</li> </ul>

## 7. Maintenance



**BEFORE PERFORMING ANY MAINTENANCE REQUIRING REAGENT HEAD OR VALVE (WET END) DISASSEMBLY, BE SURE TO RELIEVE PRESSURE FROM THE PIPING SYSTEM AND, WHERE HAZARDOUS PROCESS MATERIALS ARE INVOLVED, RENDER THE PUMP SAFE TO PERSONNEL AND THE ENVIRONMENT BY CLEANING AND CHEMICALLY NEUTRALIZING AS APPROPRIATE. WEAR PROTECTIVE CLOTHING AND EQUIPMENT AS APPROPRIATE.**

Accurate records from the early stages of pump operation will indicate the type and levels of required maintenance. A preventative maintenance program based on such records will minimize operational problems. It is not possible to forecast the lives of wetted parts such as diaphragms and check valves. Since corrosion rates and operational conditions affect functional material life, each metering pump must be considered according to its particular service conditions.

PULSAR KOPkits contain all replacement parts normally used in a preventative maintenance program. It is recommended that KOPkits and *PULSAlube* hydraulic and gear oils be kept available at all times.

Each PULSAR pump is provided with an individual specification data sheet included in the parts list package. The data sheet contains important information relating to the application along with pump serial number, pump specifications (i.e., materials, piston size, stroking rate, etc.).

### 7.1 Oil Changes

The recommended oil change intervals are dependent upon the operating environment and level of pump usage, classified as follows:

1. Normal service: clean/dry atmosphere, an ambient operating temperature of 0° C to 40° C (32° F to 104° F) and up to 2,000 annual operating hours.
2. Severe Service: humid atmosphere, an ambient operating temperature below 0° C (32° F) or above 40° C (104° F), and over 2,000 annual operating hours.

#### 7.1.1 Gear Oil Change:

The recommended gear oil change interval is five years for normal service and two years for severe service.

**Gear Oil change procedure is as follows:**

1. Disconnect the power source to the drive motor.
2. Relieve all pressure from the piping system.
3. Remove the fill plug from the top of the gearbox.
4. Drain the oil by removing the drain plug on the bottom of the gearbox.
5. Replace the drain plug.
6. Refill with fresh *PULSAlube* 8G (amber) gear oil (refer to *Gear Oil Fill, Section 5.1.2*).
7. Replace the top fill plug and side plug (if removed).

## 7.1.2 Hydraulic Oil Change:

The recommended hydraulic oil change interval is 2 years for normal service and 1 year for severe service.

**Hydraulic Oil change procedure is as follows:**

1. Disconnect the power source to the drive motor.
2. Relieve all pressure from the piping system.
3. Remove the diagnostic window from the top of the eccentric box.
4. Drain the oil by removing the drain plug on the bottom of the eccentric box.
5. Remove and clean the HPV check valve screen (refer to *Check Valve Screen – Removal and Cleaning, Section 7.4.2*).
6. Replace the drain plug.
7. Fill the eccentric box with *PULSAlube 7H* (purple) hydraulic oil (refer to *Hydraulic Oil Fill, Section 5.1.3*). Proper fill of a fully drained pump requires 1 liter (approx. 1 quart) of *PULSAlube 7H* oil.
8. Replace the diagnostic window.

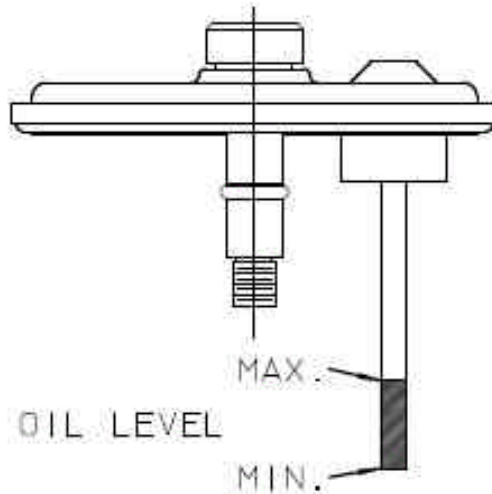

## 7.2 Wet End Removal, Inspection, and Reinstallation



WARNING

If the diaphragm has failed, process material may have contaminated the pump hydraulic oil. Handle with appropriate care, clean and replace oil if required.



NOTE

### PULSAlarm Leak Detection System

See Appendix I, page 32 for information on maintenance of the PULSAlarm Leak Detection diaphragm

## 7.2.1 Standard Diaphragm Replacement

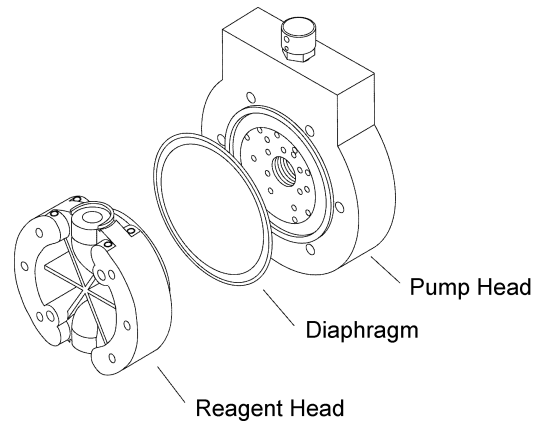

Figure 14

PULSAR diaphragms do not have a specific cycle life; however, the accumulation of foreign material or the entrapment of sharp particles between the diaphragm and dish cavity can eventually cause failure. Failure can also occur as a result of hydraulic system malfunction or chemical attack. Periodic diaphragm inspection and replacement are recommended.

### Diaphragm Replacement Procedure:

1. Disconnect the power source to the drive motor
2. Relieve all pressure from the piping system.
3. Take all precautions to prevent environmental and personnel exposure to hazardous materials.
4. Close the inlet and outlet shutoff valves.
5. Place a suitable container underneath the pump head to catch any liquid leakage.
6. Disconnect piping to the reagent head and drain any process liquid, following material safety precautions described.
7. Remove all but one top reagent head bolt. Oil will leak out between the pump head and reagent head as the bolts are loosened.
8. Tilt the head and pour out any liquids retained by the check valves into a suitable container, continuing to follow safety precautions as appropriate.
9. Remove the final bolt and rinse or clean the reagent head with an appropriate material.
10. Remove and inspect the diaphragm. It may have taken a permanent convex/concave set as a result of normal flexure and conformance to the dishplate. This condition is normal and is not cause for replacement. The diaphragm must be replaced if it is deformed, dimpled, or obviously damaged.
11. To install a diaphragm, first ensure that the critical sealing areas of diaphragm, reagent head, and pump head are clean and free of debris. Set the diaphragm in place on the reagent head and ensure seating of the diaphragm sealing ring into the mating groove in the reagent head.
12. Install the reagent head bolts and tighten in an alternating pattern to ensure an even seating force. Torque to the values recommended in *Appendix IV*.
13. Re-prime the pump head, see *Section 7.2.2*.



**When reinstalling a used diaphragm it is not necessary to maintain the previous orientation relative to the reagent head or pump head hole pattern.**

NOTE

## 7.2.2 Re-Priming the Pumphead

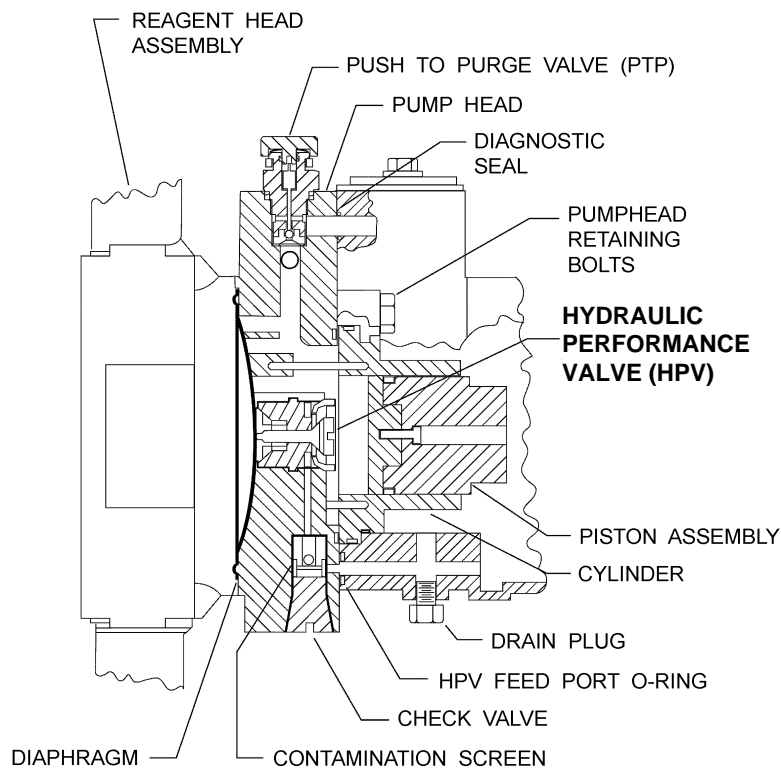

**Leak Detection diaphragm systems require special hydraulic priming considerations to protect the diaphragm from damage during initial pump startup. Refer to Appendix I, page 33 and review these procedures carefully before re-starting a PULSAR pump equipped with a leak detection system.**

Figure 15

### **Hydraulic Priming Procedure, for standard Composite (THY) and Solid (PTFE) diaphragms:**

1. Disconnect the power source to the drive motor.
2. Relieve all pressure from the piping system and where possible allow liquid to enter the reagent head assembly.
3. Remove the diagnostic window and fill the eccentric box with *PULSA*lube 7H hydraulic oil to the proper level. Replace the diagnostic window.
4. Turn on the pump and adjust the stroke length to the maximum setting of 100%.
5. Fully depress and hold the PTP valve. After several minutes oil should begin to flow out of the center diagnostic port. Continue to hold the valve down until the oil is clear of bubbles. The pump is now primed. If oil fails to flow out of the diagnostic port, proceed to step 6.
6. **Reset to the zero stroke length setting**, and turn off the pump. Setting the pump to zero stroke moves the piston forward to prevent diaphragm damage at startup.
7. Remove the PTP valve from the pumphead. Using a small plastic funnel, slowly pour oil into the pumphead through the PTP valve port until full.
8. Replace the PTP valve, ensuring that the flat copper gasket and o-ring are properly in place.
9. Turn on the pump. Gradually raise the stroke to the full 100% setting. Fully depress and hold the PTP valve. Oil should begin to flow out of the center diagnostic port. Continue to hold the valve down until the oil is clear of bubbles. If oil fails to flow out of the diagnostics port, then additional oil is required in the pumphead: repeat steps (6) and (7) above.

## 7.3 Check Valves

### 7.3.1 General Description

Most fluid metering problems are related to check valves. Problems usually stem from solids accumulation between valve and seat, corrosion of seating surfaces, erosion, or physical damage due to wear or the presence of foreign objects.

The valve incorporates a ball, guide, and seat. Flow in the unchecked direction lifts the ball off the seat, allowing liquid to pass through the guide. Reverse flow forces the ball down, sealing it against the sharp edge of the seat. The guide permits the ball to rotate but restricts vertical and lateral movement in order to minimize “slip” or reverse flow. Ball rotation prolongs life by distributing wear over the entire surface of the ball. Since ball return is by gravity, the valve must be in the vertical position in order to function properly. Parts are sealed by o-rings.

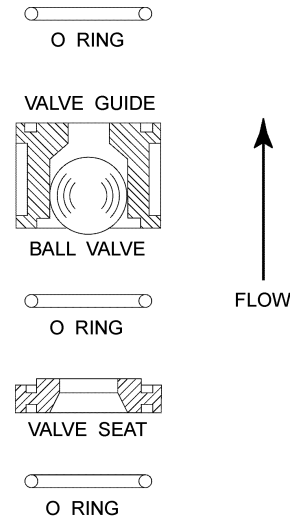

### 7.3.2 Removal, Inspection, and Reinstallation

Use the following procedure to remove, inspect and reinstall the check valves:

1. Disconnect the power source to the drive motor.
2. Relieve all pressure from the piping system.
3. Take all precautions to prevent environmental and personnel exposure to hazardous materials.
4. Close the inlet and outlet shutoff valves.
5. Loosen the suction valve tiebar bolts and spring the suction piping slightly to drain any liquid from the reagent head cavity. If the piping is closely connected it may be necessary to disconnect a union or flange.
6. Remove the suction check valve assembly (ball contained within guide and seat), holding it together as a unit.
7. Loosen the tiebar bolts on the discharge valve and spring the piping slightly to drain any liquid.
8. Remove the discharge check valve assembly, holding it together as a unit as before.
9. Disassemble both valves and examine components for wear. Seats should have sharp edges or a small chamfer, free from dents or nicks. Hold the ball firmly against its mating seat in front of a bright light to inspect for fit.



**Observation of light between ball and seat is cause for replacement of either or both components. For best results, always loosen the unions or flanges on either side of the system piping prior to re-tightening of the check valve assemblies. Retighten the unions or flanges after the check valves are securely tightened into position.**

10. Reassemble both valves using new parts as required. Sealing o-rings should always be replaced.
11. Reinstall both valve assemblies, taking care to ensure that they are correctly oriented with balls above seats.
12. Tighten the tiebar bolts evenly, making sure the valve assemblies are assembled squarely. Refer to *Appendix IV* for torque values.
13. Check for leaks and retighten tiebar bolts as necessary.

## 7.4 Hydraulic Performance Valve (HPV)

### 7.4.1 General Description

During normal pump operation hydraulic fluid is continually discharged through the automatic bleed valve and may also be lost past the piston seals. This causes the diaphragm to be drawn further back on each successive suction stroke until it actuates the HPV. Once the valve is actuated, oil is allowed to flow into the hydraulic system until the piston reaches the end of the suction stroke. As the piston starts forward a check valve prevents oil from flowing back through the HPV, thereby allowing the valve to close as the diaphragm moves forward. Through this process the diaphragm is continually maintained in a proper operating position relative to the pumphead dish-plate. Since the HPV is unaffected by the vacuum level in the pumphead, oil cannot be inadvertently brought into the hydraulic system which would result in over-extension and damage to the diaphragm. This feature provides pump protection should the suction line become restricted or closed.

PULSAR pumps utilize two styles of High Performance Valves (refer to **Figure 17**) dependent on the pumphead size. Although different in appearance they function identically. The valves are factory preset and require no maintenance provided the hydraulic oil remains clean. The check valve in series with the HPV includes a screen to trap contaminants (refer to **Figure 15**) and should be removed and cleaned with each change of the hydraulic oil as indicated below. A clogged filter screen will impede the operation of the HPV, and can lead to diaphragm damage. Should the HPV require removal for cleaning or replacement, follow the procedure appropriate to the valve style. If a diaphragm has failed, and chemical has contaminated the pump head assembly, both the HPV and the HPV check should be removed and thoroughly cleaned.

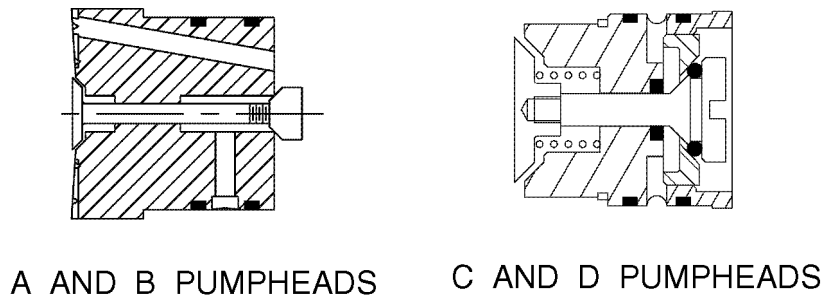

Figure 17

### 7.4.2 Check Valve Screen - Removal and Cleaning

Use the following procedure to remove and clean the Check Valve screen (refer to **Figure 15**) It is easiest to perform this process during an oil change:

1. Disconnect the power source to the drive motor
2. Relieve all pressure from the piping system.
3. Drain hydraulic fluid from the eccentric box.
4. Unscrew the check valve from the bottom of pump head.
5. Clean the valve and screen in a solvent compatible with the nitrile seal material and blow air through the valve to remove all contaminants.
6. Inspect the copper gasket and o-ring for nicks or other damage and replace if necessary.
7. Lubricate the o-ring with *PULSAlube 7H* and replace the valve, tightening securely.
8. Re-install the eccentric box drain plug and refill with *PULSAlube 7H* hydraulic oil.

### 7.4.3 HPV Removal and Replacement - A & B Pumphead Style

Use the following procedure for a HPV Removal and Replacement (A & B Pumphead Style)

1. Remove the reagent head and diaphragm, and drain hydraulic oil from the eccentric box.
2. Remove the four bolts on the front eccentric box flange which retain the pumphead. The piston return spring is under compression and will force the pumphead/cylinder away from the eccentric box as the bolts are removed.
3. Remove the seal retainer nut from the pumphead cylinder (refer to **Figure 18**).
4. Remove the four socket head capscrews that retain the cylinder to the pumphead (refer to **Figure 18**) and remove the cylinder, taking care to not lose the copper gasket.
5. Select a socket or spacer which fits into the cylinder side bore of the pumphead and also clears the rear poppet of the HPV (refer to **Figure 18**).
6. Exert pressure on the socket or spacer to press the HPV out of the pumphead.
7. If cleaning of the valve is required, use a suitable solvent and blow air through the valve to remove all contaminants.
8. Inspect the o-rings on the body of the valve for nicks or other damage and replace if required.
9. Lubricate the o-rings with *PULSAlube 7H* and carefully insert the HPV into the dish side bore of the pumphead. Rotate the valve so that the hole and slot farthest from the center are aligned with the corresponding slot in the pumphead. Using a socket or spacer which clears the front poppet, press the valve into the pumphead until it is fully seated.

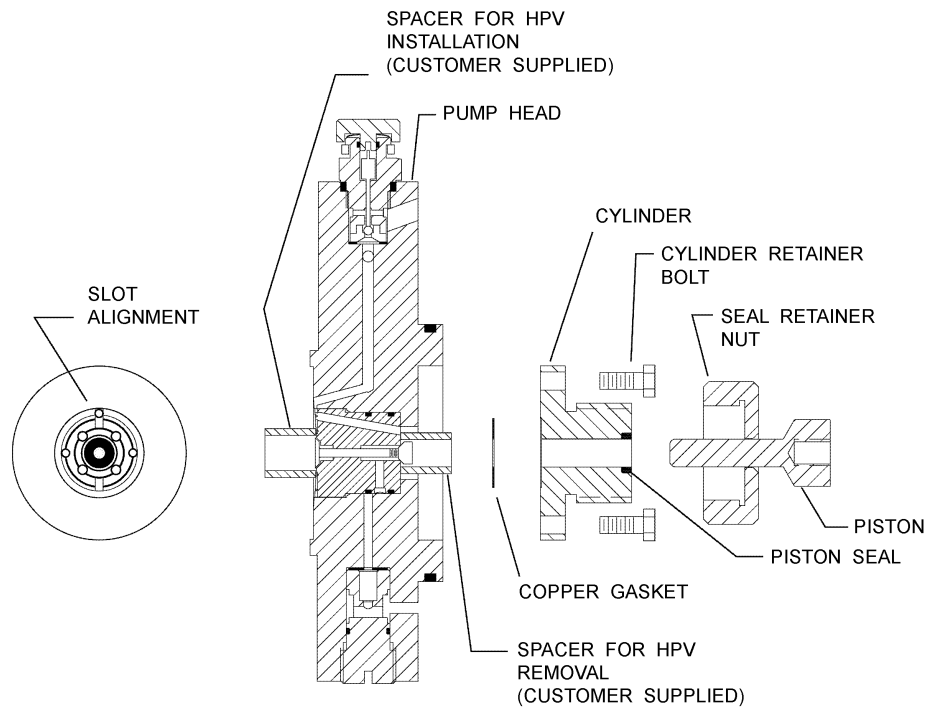

Figure 18

10. Reinstall the cylinder, copper gasket, and seal retainer nut.
11. Inspect the o-ring on the pumphead locating shoulder for nicks or other damage, replace if necessary, and lubricate with *PULSAlube 7H*.

continues next page...

12. Make certain that the diagnostics seal at the top of the eccentric box flange and the HPV feed port o-ring at the bottom of the flange are in place (refer to **Figure 4**).
13. Insert the pumphead into the eccentric box using the locating pins as a guide.
14. Some compression of the piston return spring will be required in order to start the pumphead retaining bolts after which the bolts can be tightened to complete installation of the head. Spring compression will be minimized with the eccentric in the retracted position and the stroke setting at 100%.
15. Reinstall the diaphragm and reagent head.
16. Re-install the eccentric box drain plug and fill with *PULSA*lube 7H hydraulic oil.
17. Re-prime the pump.

#### 7.4.4 HPV Removal and Replacement - C & D Pumphead Style

Use the following procedure for a HPV Removal and Replacement (C & D Pumphead Style)

1. Remove the reagent head and diaphragm.
2. Drain hydraulic fluid from the eccentric box.
3. Remove the four bolts on the front eccentric box flange which retain the pumphead. the piston return spring is under compression and should force the pumphead/cylinder away from the eccentric box as the bolts are removed. If the cylinder separates from the pumphead, remaining in the eccentric box, it may be necessary to remove the eccentric box cover and tap out the cylinder from behind.
4. The cylinder is retained to the pumphead by two roll pins. Separate the cylinder by prying on the groove above the o-ring (refer to **Figure 19**).
5. Using a hex wrench, unscrew the HPV from the cylinder side of the pumphead.
6. If cleaning of the valve is required, use a solvent compatible with nitrile seals and blow air through the valve to remove all contaminants.
7. Lubricate the o-rings with *PULSA*lube 7H and carefully insert the HPV into the back of the pumphead, make certain that the threads are properly engaged before tightening.
8. Align the roll pins to the appropriate holes and press the cylinder onto the pumphead, make certain that the o-ring on the back side of the pumphead is in place

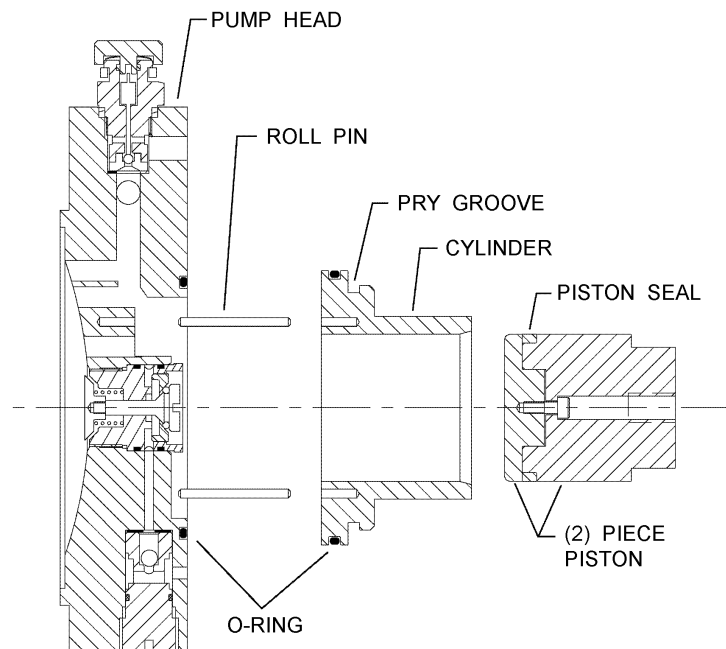

Figure 19

9. Inspect the o-ring on the cylinder locating shoulder for nicks or other damage and replace if necessary, lubricate with *PULSA*lube 7H.
10. Make certain that the diagnostics seal at the top of the eccentric box flange and the HPV feed port o-ring at the bottom of the flange are in place (refer to *Figure 4*).
11. Insert the pumphead onto the eccentric box using the locating pins as a guide.
12. Some compression of the piston return spring will be required in order to start the pumphead retaining bolts after which the bolts can be tightened to complete installation of the head. Spring compression will be minimized with the eccentric in the retracted position and the stroke setting at 100%.
13. Reinstall the diaphragm and reagent head.
14. Reinstall the eccentric box drain plug and fill with *PULSA*lube 7H hydraulic oil.
15. Re-prime the pump.

## 7.5 Hydraulic Bypass Valve (HBV)

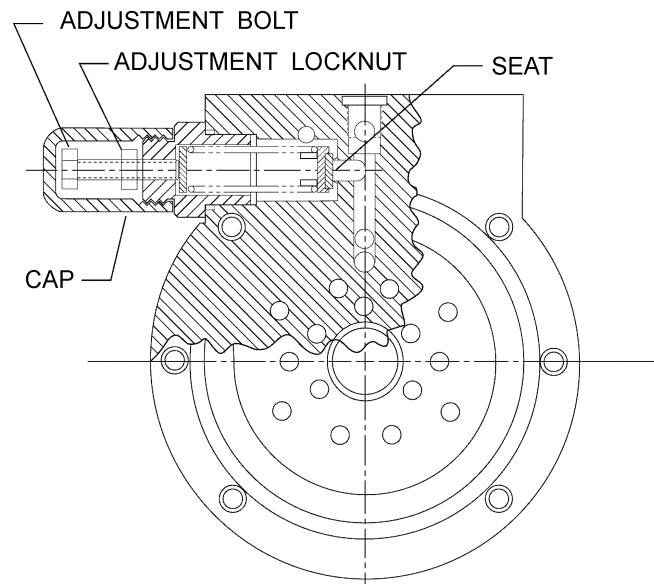

Figure 20

All PULSAR pumps incorporate a Hydraulic Bypass Valve which is an adjustable spring-loaded valve ported into the hydraulic cavity of the pumphead. The valve is designed to protect the pump against excessive hydraulic pressure and will not limit or regulate system pressure. The valve is factory-adjusted for pressure as originally specified, or at 10% above the rated pump pressure.

The HBV is located at the top of the pumphead and any discharge, indicating over pressurization, is visible at the outer diagnostics port. To adjust the valve, remove the valve's plastic cover, loosen the lock-nut, and turn the adjustment screw clockwise (as seen facing the screw) to increase the bypass pressure and counterclockwise to decrease it. The locking nut must be tightened after adjustment.

Pump damage may occur during a system upset, if the hydraulic bypass pressure is set higher than 10% over the design pressure of the pump. Conversely, if the setting is too low the valve will operate on each discharge stroke. This results in decreased pumping capacity and will eventually affect the efficiency of the valve.

To check the hydraulic bypass pressure setting, install a gauge and a regulating valve in the pump discharge line. The gauge must be between the pump and valve. For convenience, locate the two as close to the pump as possible. With the pump operating at maximum stroke length, gradually

increase the discharge pressure and observe when the HBV starts to operate. The cracking pressure of the valve must be at least as high as the maximum pressure of the system but no more than 10% over the pump's rated pressure. After adjustment tighten the lock nut and reinstall the plastic cover. Periodic inspection of the valve seat is recommended. If it becomes worn or damaged leakage will occur regardless of how tightly the valve is adjusted.

## **7.6 PTP (Push to Purge / Automatic Bleed Valve)**

### **7.6.1 General Description**

The PTP (automatic bleed valve) is a gravity-operated ball check valve that automatically removes gases from the hydraulic system. On each discharge stroke of the pump, hydraulic pressure drives the ball off the lower seat, expelling any accumulation of gases at the top of the hydraulic system. An upper seat limits ball travel and flow during each actuation. On each suction stroke, the ball is pre-positioned by gravity against the lower seat to prevent reentry of gas into the system. When all gas has been expelled, a small amount of oil will be displaced on each discharge stroke. This oil is returned by gravity to the hydraulic reservoir. Under normal operating conditions this ongoing process removes minute, invisible accumulations of gas long before they are visible or detrimental to pump operation. To accelerate hydraulic startup, pressing the spring-loaded button at the top of the valve holds the valve momentarily open so that large amounts of gas can be instantly purged. When the button is released, the valve reverts to normal automatic operation. Bleed valve operation can be monitored by observing oil flow from the center discharge port through the diagnostic window. Any accumulation of solids can cause the valve to malfunction.

### **7.6.2 Removal, Cleaning, & Reinstallation**

**Use the following procedure to remove, clean & reinstall the PTP (Automatic Bleed Valve)**

1. Disconnect the power source to the drive motor.
2. Relieve all pressure from the piping system.
3. Slowly unscrew the valve to gradually relieve any residual hydraulic system pressure.
4. Remove the valve and clean it by soaking in compatible solvent. Valve operation can be confirmed by blowing air through it in both directions and listening for the "click" sound of ball-seat contact in both directions.
5. Make sure that the copper gasket is installed at the bottom of the threaded hole in the pump head. It need not be replaced provided that it is sound and undamaged. The elastomer gasket around the upper portion of the valve assembly may be likewise re-used.

This valve is not repairable and must be replaced if it continues to malfunction after cleaning.

## 7.7 Piston Seal

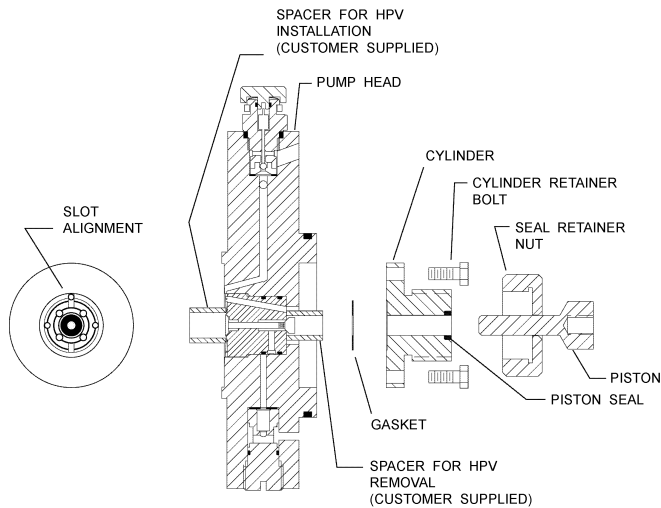

Figure 21

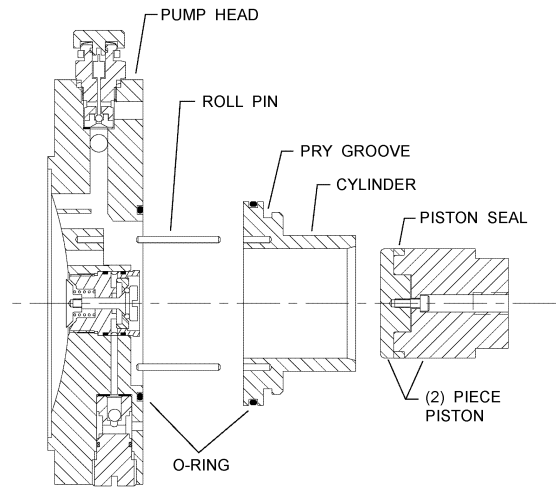

Figure 22

### 7.7.1 General Description

The piston seals are of carbon graphite reinforced TFE U-cup construction with a stainless steel energizer spring. The seal is mounted two different ways: on the piston (for the larger piston sizes – *Figure 22*) or in the cylinder (for the smaller piston sizes – *Figure 21*). With oil changes at recommended intervals, piston seals should give years of service.

### 7.7.2 Removal

**Use the following procedure to remove the Piston Seal:**

1. Remove the reagent head and diaphragm.
2. Remove the four bolts that secure the pumphead to the eccentric box and withdraw the pumphead. Take care not to lose the oval gasket and the o-ring on the face of the eccentric box.
3. For larger piston sizes (seal installed on piston), withdraw the crosshead/piston assembly from the eccentric box. Unscrew the piston from the crosshead and remove the socket head capscrew inside the piston, withdraw the front of the piston, and remove the large seal.
4. For smaller piston sizes (seal installed in cylinder), unscrew the seal retaining nut from the cylinder and withdraw the seal from the counterbore.

### 7.7.3 Reinstallation

Reinstallation is the reverse of removal. In the case of the larger piston sizes (seal installed on piston), it is important to apply an anaerobic thread-locking compound to the threads of the piston-crosshead connection and the capscrew to prevent loosening during operation. Apply *PULSA*lube 7H hydraulic oil to seals prior in installation to facilitate assembly and for startup. Fill the eccentric box with *PULSA*lube 7H hydraulic oil and prime the pump head.

## 7.8 Oil Seals

### 7.8.1 General Description

The pump has three oil seals as follows:

- Motor Adapter Seal – Inside the motor adapter, below the worm shaft coupling.
- Gearbox Oil Seal – Inside the end play adjustment cap on the side of the gearbox.
- Eccentric Box Seal – Surrounding the eccentric shaft, where it protrudes from the box.

### 7.8.2 Removal and Replacement

**Use the following procedure to remove and replace the motor adaptor seal:**

1. Remove the motor.
2. Loosen the coupling setscrew through the access plug hole in the motor adapter and remove the worm coupling half.
3. Remove the four motor adapter bolts and withdraw the motor adapter from the gearbox. Take care not to lose the shims from between motor adapter and gearbox.
4. Remove the oil seal from the motor adapter. Lubricate the replacement seal with *PULSA*lube 8G gear oil and install by pressing into position.
5. Reassemble by reversing the above disassembly procedure.

**Use the following procedure to remove and replace the gearbox oil seal:**

1. Drain the gearbox.
2. Remove the four gearbox bolts, and withdraw the gearbox from the eccentric box, sliding it off the eccentric shaft.
3. Remove the seal.
4. Lubricate the replacement seal with *PULSA*lube 8G gear oil and install by pressing into position.
5. Reinstall by reversing the disassembly procedure.
6. Refill the gearbox with *PULSA*lube 8G gear oil.

**Use the following procedure to remove and replace the eccentric box seal:**

1. Remove the gearbox.
2. Remove the four bolts that retain the eccentric side cap to the eccentric box.
3. Remove the eccentric side cap and withdraw the eccentric shaft.
4. Remove the seal.
5. Lubricate the replacement seal with *PULSA*lube 8G gear oil and install by pressing into position.
6. Reinstall by reversing the disassembly procedure.
7. Refill the gearbox with *PULSA*lube 8G gear oil.

## 7.9 Cover Assembly

### 7.9.1 Removal & Reinstallation

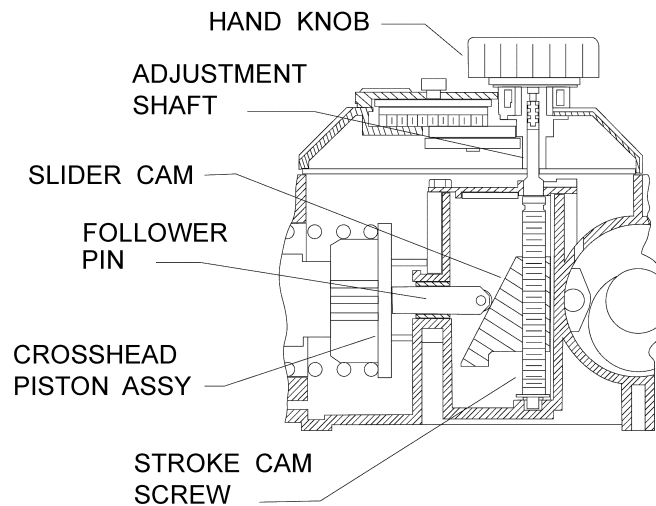

Figure 23



**The hand knob linkage employs a slip type coupling which can be reassembled in either of two rotational orientations 180° apart from one another: therefore, the original orientation must be retained for reassembly so that pump calibration is retained.**

**Use the following procedure to remove the cover assembly:**

1. Adjust the stroke length until the dial indicator is set at the zero stroke setting.  
Adjustment is easier with the drive motor running. Allow the locking mechanism to engage to the nearest détente.
2. Disconnect the power source to the drive motor.
3. Remove the cover screws.
4. Using care not to rotate the adjustment shaft, remove the cover vertically from the eccentric box.

**Use the following procedure to reinstall the cover assembly:**

1. Rotate the stroke cam screw clockwise until the slider cam is in a full upward position.
2. Verify that the cover dial indicates the zero stroke setting.
3. Using care not to disturb the adjustment shaft, install the cover assembly, engaging the drive coupling.
4. Replace the cover bolts, and tighten to 20-24 In-lb (225 – 270 N-cm)..
5. Press the adjustment knob down and rotate it clockwise until it stops.  
Adjustment is easier with the drive motor running.
6. Verify that the cover dial indicates the zero stroke setting as before; if so, reinstallation is complete and if not, refer to step (7) below for realignment.
7. Loosen the screw in the center of the dial cover.
8. Adjust the dial cover to align the pointer with the “zero” mark.
9. Retighten the screw in the center of the dial cover.

## 8. Pump Motor

### 8.1 Removal & Reinstallation

Use the following procedure to remove and reinstall the pump motor:

1. Disconnect the power source to the drive motor.
2. Disconnect the motor wiring from the motor.
3. Remove the four bolts retaining the motor to the motor adaptor and remove the motor.  
The coupling is an interlocking jaw design and uses an elastomer spider between the two coupling halves. One half of the coupling remains on the worm shaft and the other coupling half on the motor shaft (refer to *Figure 6* and *Figure 11*).
4. Loosen the setscrew that retains the coupling half to the motor shaft and remove the coupling half, taking care to not lose the shaft key.
5. Install the coupling half on the shaft of the replacement motor, ensuring that the shaft key is in place.
6. Align the end of the shaft flush with the inner surface of the coupling and tighten the setscrew.
7. Reinstall the motor by reversing steps (3) through (1) above.

## 9. Replacement Parts

### 9.1 PULSAR KOPkit Program

PULSAR KOPkits contain all replacement parts normally used in a preventative maintenance program. (*PULSAlube 7H* hydraulic and *PULSAlube 8G* gear oils are also available for preventative maintenance programs.) There is a specific KOPkit for every PULSAR pump model. Each KOPkit is vacuum-packed for extended storage. All PULSAR pumps have the KOPkit number identified on the pump nameplate, the specification data sheet, and Pulsafeeder order documents. KOPkits can also be selected from the technical data sheet shipped with the pump or by a Pulsafeeder representative.

### 9.2 Ordering KOPkits or Parts

When ordering replacement parts always specify:

- Pump model and serial number (stamped on pump nameplate), e.g., Model No. 55H with Serial No. 9676303-1.
- Part number and description from the PULSAR parts list. Include the three-character suffix. (Note: PULSAR part numbers begin either with the letters “NP”, or the letter “W”, e.g., NP170001-TNR or W210221-001.)

# 10. Troubleshooting Chart

Difficulty	Probable Cause	Remedy
<b>Pump does not start.</b>	<ol style="list-style-type: none"> <li>1. Coupling disconnected.</li> <li>2. Faulty power source.</li> <li>3. Blown fuse, and circuit breaker.</li> <li>4. Broken wire.</li> <li>5. Wired improperly.</li> <li>6. Pipe line blockage.</li> </ol>	<p>Connect coupling.            Check power source.            Replace - eliminate overload.            Locate and repair.            Check diagram.            Open valves.</p>
<b>No delivery.</b>	<ol style="list-style-type: none"> <li>1. Motor not running.</li> <li>2. Supply tank empty.</li> <li>3. Lines clogged.</li> <li>4. Closed line valves.</li> <li>5. Ball check valves held open with solids.</li> <li>6. Vapor lock, cavitation.</li> <li>7. Prime lost.</li> <li>8. Strainer clogged.</li> <li>9. Hydraulic system under-primed.</li> </ol>	<p>Check power source. Check wiring diagram.            Fill tank.            Clean and flush.            Open valves.            Clean and inspect.</p> <p>Increase suction pressure.            Reprime, and check for leak.            Remove and clean. Replace screen if necessary.            Refer to <b>Repriming the Pump</b>.</p>
<b>Low delivery.</b>	<ol style="list-style-type: none"> <li>1. Motor speed too low.</li> <li>2. Check valves worn or dirty.</li> <li>3. Hydraulic bypass valve operating each stroke.</li> <li>4. Calibration system error.</li> <li>5. Product viscosity too high.</li> <li>6. Product cavitating.</li> <li>7. Piston seal worn or damaged by contamination.</li> <li>8. Process pressure relief valve leaking or relieving</li> </ol>	<p>Check voltages, frequency, wiring, and Terminal connections. Check nameplate vs. Specifications.            Clean, replace if damaged.            Refer to <b>Hydraulic Bypass Valve</b>.</p> <p>Evaluate and correct.            Lower viscosity by increasing product temperature. Increase pump and/or piping size.            Increase suction pressure. Cool product as necessary.            Inspect and replace if necessary, refer to <b>Piston Seal</b>.            Repair, adjust or replace</p>
<b>Delivery gradually drops.</b>	<ol style="list-style-type: none"> <li>1. Check valve leakage.</li> <li>2. Leak in suction line.</li> <li>3. Strainer fouled.</li> <li>4. Product change.</li> <li>5. Bypass leakage.</li> <li>6. Piston seal worn or damaged by contamination.</li> <li>7. Supply tank vent plugged.</li> </ol>	<p>Clean, replace if damaged.            Locate and correct.            Clean or replace screen.            Check viscosity.            Correct for bypass valve leakage.            Inspect and replace if necessary, refer to <b>Piston Seal</b>.            Unplug vent.</p>
<b>Delivery erratic.</b>	<ol style="list-style-type: none"> <li>1. Leak in suction line.</li> <li>2. Product cavitating.</li> <li>3. Entrapped air or gas in product.</li> <li>4. Motor speed erratic.</li> <li>5. Fouled check valves.</li> </ol>	<p>Locate and correct.            Increase suction pressure.            Consult factory for suggested venting.            Check voltage and frequency.            Clean, replace if necessary.</p>
<b>Delivery higher than rated.</b>	<ol style="list-style-type: none"> <li>1. Suction pressure higher than discharge pressure.</li> <li>2. Back pressure valve set too low.</li> <li>3. Back pressure valve leaks.</li> <li>4. Calibration error</li> </ol>	<p>Install backpressure valve or consult factory for piping recommendations.            Increase setting.            Repair, clean, or replace.            Review calculations</p>

## Troubleshooting Chart (cont.)

Difficulty	Probable Cause	Remedy
<b>Pump loses hydraulic oil.</b>	<ol style="list-style-type: none"> <li>1. Diaphragm ruptured.</li> <li>2. Leaky seal.</li> <li>3. Cover gasket leaks.</li> <li>4. Pump head gasket leaks.</li> <li>5. Pump head overfilled.</li> </ol>	<p>Replace. Replace. Replace or retighten. Replace - tighten pump head bolts. Apply sealing compound. Remove excess oil.</p>
<b>Air bleeds continuously from PTP (automatic bleed valve)</b>	<ol style="list-style-type: none"> <li>1. Hydraulic oil level low.</li> <li>2. Hydraulic bypass valve operating each stroke.</li> <li>3. Suction pressure too low.</li> <li>4. Breakdown of oil – temperature high.</li> </ol>	<p>Refill to correct level. Refer to <i>Hydraulic Bypass Valve</i>.  Increase pressure. Change oil type, consult factory.</p>
<b>Noisy gearing, knocking</b>	<ol style="list-style-type: none"> <li>1. Discharge pressure too high.</li> <li>2. Water hammer.</li> <li>3. Hydraulic bypass valve set too high.</li> <li>4. Stroke length at partial setting.</li> </ol>	<p>Reduce pressure. Install <i>PULSA</i>trol. Readjust (refer to <i>Hydraulic Bypass Valve</i>).  Nondestructive knocking is characteristic of lost motion pumps.</p>
<b>Piping noisy</b>	<ol style="list-style-type: none"> <li>1. Pipe size too small.</li> <li>2. Pipe runs too long.</li> <li>3. Surge chambers flooded.</li> <li>4. No surge chambers used.</li> </ol>	<p>Increase size of piping - install <i>PULSA</i>trol. Install <i>PULSA</i>trol in line. Replace with air or inert gas. If a <i>PULSA</i>trol is installed, replace diaphragm and recharge. Install <i>PULSA</i>trol.</p>
<b>Motor overheats</b>	<ol style="list-style-type: none"> <li>1. Pump overloaded.</li> <li>2. High or low voltage.</li> <li>3. Loose wire.</li> </ol>	<p>Check operating conditions against pump design. Check power source. Trace and correct.</p>
<b>PULSA Alarm Leak Detection – False Alarm</b>	<ol style="list-style-type: none"> <li>1. Vacuum/pressure leak.</li> <li>2. Switch adjustment off.</li> <li>3. Switch malfunction.</li> <li>4. Insufficient vacuum.</li> </ol>	<p>Find and correct. Readjust switch. Replace switch. Evacuate to specification.</p>
<b>PULSA Alarm Leak Detection – Failure to Alarm</b>	<ol style="list-style-type: none"> <li>1. Switch adjustment off.</li> <li>2. Switch malfunction.</li> <li>3. Power off.</li> <li>4. Alarm wiring discontinuity.</li> </ol>	<p>Readjust switch. Replace switch. Restore power. Find and correct.</p>

## 10.1 Diagnosis of Diaphragm Failure

The following guide provides some potential causes of diaphragm failure; it is based upon visual observation of the diaphragm. Careful observation of both the pump and the surrounding system is necessary for proper diagnosis. This is only a guide, and may not include all potential causal factors.

Failure Observed	Potential Causes
Puncture, surface wear, or physical damage	Abrasives or solids in the process stream Foreign object in process or hydraulic system
Extrusion and/or failure to the front (towards the process end)	Extended time under poor suction conditions, can include inadequate NPSH, closed valves, clogged strainers or filters, obstructed piping Malfunctioning HPV
Extrusion and/or failure to the rear (towards the hydraulic end)	HPV filter screen clogged High (excessive) suction pressure Discharge pressure above maximum limit Leaking (damaged) discharge check valve
Change in surface characteristics, color, smoothness	Chemical incompatibility with the product

# 11. Appendix I PULSAlarm Leak Detection System

## 11.1 PULSAlarm Leak Detection Reagent Head Assembly

The PULSAlarm leak detection reagent head assembly consists of reagent head, leak detection diaphragm, suction and discharge check valves, vacuum bleed port, and optional pressure/vacuum switch and gauge. The reagent head, diaphragm, suction and discharge check valves are the only parts of the pump to contact the process liquid; consequently, maintenance is critical to pump performance

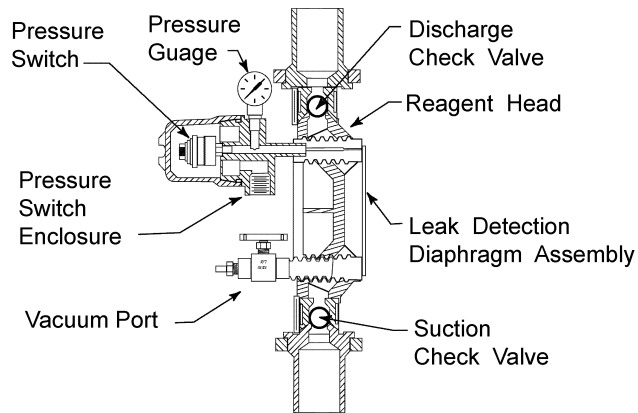

Figure 24



**A sealed system must be maintained at all times during pump operation, whether leak detection is required or not. If the proper level of vacuum, between 10 in. and 26 in. (250mm to 650mm) Hg, or a sealed pressure system is not present, decreased flow and/or diaphragm damage will occur. Please note that the factory setpoint for actuation of the vacuum switch is 6 in (152mm) Hg (vacuum) or 5 psig (pressure).**

## 11.2 PULSAlarm Leak Detection Diaphragm

Double, or sandwiched, TFE diaphragms are sealed at their peripheries to an intermediate metal spacer ring. The space between the diaphragms is sealed so that the diaphragm functions as does a standard single diaphragm. For the vacuum system, the space between the diaphragms is evacuated of air to produce a vacuum. For the pressure system, the space between the diaphragms is filled with a small amount of fluid. At startup, any excess fluid in the system is expelled through the check valve, and then the system is capped and sealed. The fluid as supplied from the factory is a silicone-based oil, but an alternate fluid can be used if compatibility with the materials of construction is verified. This space is connected to an adjustable electrical switch (optional) that actuates in response to loss of vacuum or buildup of pressure resulting from rupture of either or both diaphragms. Switch operation can be used to perform any external function, typically to signal an alarm or turn off the pump. For component location refer to *Figure26*.



**PULSAlarm leak detection can utilize a vacuum or pressure detection system. Although both systems are similar, they do utilize different parts and require specific set-up procedures. Always ensure that you are following the procedure correct for your system.**

## 11.3 Leak Detection Option – Setup for Vacuum

A vacuum must be maintained at all times during pump operation, otherwise, the diaphragm halves may separate during the suction stroke of the pump, reducing flow capacity and potentially damaging the diaphragm.

Pumps incorporating the leak detection option are shipped from the factory with the system evacuated to the operating vacuum of 650 mm Hg (26 in. Hg). Due to flexure of the TFE diaphragms during transit and storage, the initial vacuum may not be present at startup. When this occurs, re-evacuate the system to the operating vacuum of 650 mm Hg (26 in. Hg).

1. Apply power to the alarm circuit.
2. Connect a vacuum pump capable of generating 26 inches of vacuum to the Vacuum port, open the needle valve, and evacuate the system. A hand-operated vacuum pump is generally appropriate for this procedure.
3. If required, verify system operation.

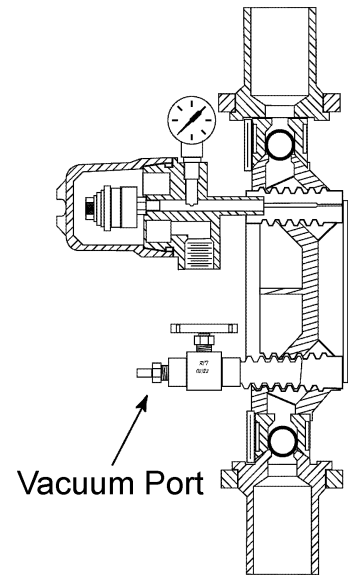

Figure 25

## 11.4 Leak Detection Option – Setup for Pressure

Pumps incorporating pressure leak detection are shipped from the factory with the system fully set up to work at full pump pressure. No further setup is required. The standard factory barrier fluid is silicone oil, if any other customer-specified media is used it must be compatible with construction materials. The system will require proper setup after maintenance or repairs, see section 11.5 on the following page for the proper procedure.

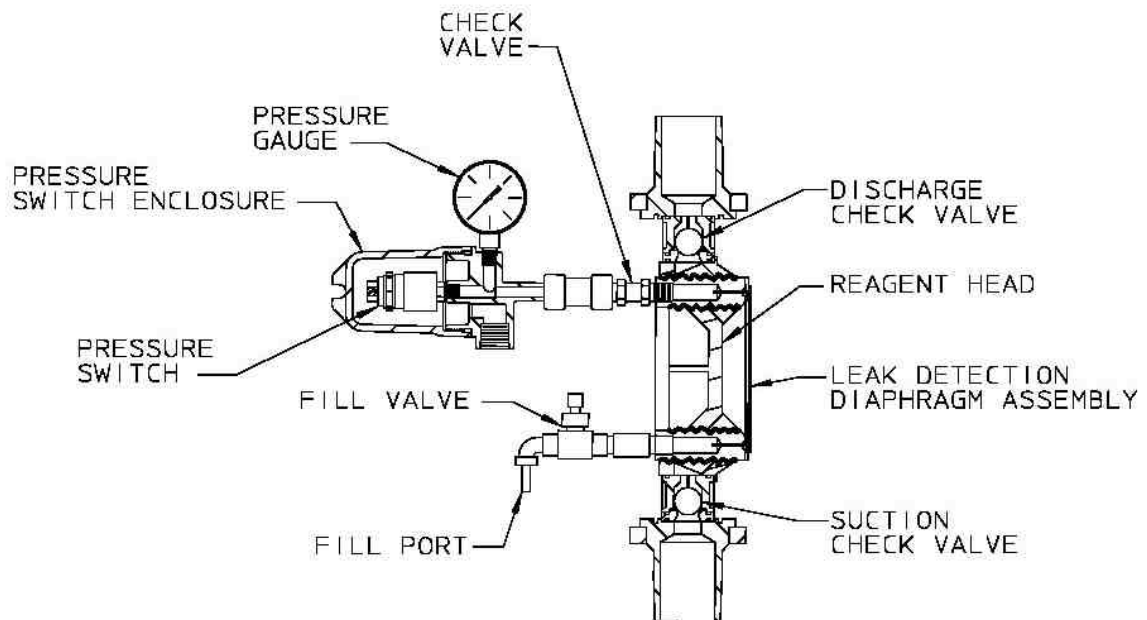

Figure 26

## 11.5 Pressure System Set-up and Priming



If the pressurized leak detection system is opened to the atmosphere during maintenance or inspection, the system must be re-primed properly to avoid diaphragm damage and ensure proper leak detection operation and system performance.



The standard factory intermediate fluid is a Silicone oil. If any other customer-specified media is used, it must be compatible with the materials of construction. Refer to the fluid manufacturer's literature for appropriate safety precautions.

Use the following procedure to set-up the pressurized leak-detection system:

1. Complete re-assembly of the diaphragm, reagent head, and external components. **Ensure that reagent head and tie-bar bolts are tightened according to the appropriate torque specifications** (consult Appendix IV)
2. Remove the pressure gauge from the housing body and replace with the straight tubing connection supplied with the pump or conversion kit. Connect a vacuum supply (hand vacuum pump) to the tube fitting.



If the system was previously sealed, you may need to remove the plug and re-install the hose fittings at the fill port. There should be a container in the vacuum line to trap excess barrier fluid. An inexpensive automotive brake bleeding kit is appropriate for this purpose.

3. Connect the fill tube, supplied with the replacement diaphragm, to the fill valve tubing connection. Any short length of the appropriate sized tubing may be used for this purpose.
4. Open the fill valve.
5. Place the fill tube into a container of the barrier fluid being used.
6. Apply vacuum, the fluid should rise into the fill tube and enter the system.
7. Observe the fluid at the exit (vacuum pump) side. When clear, air free fluid is observed, close the fill valve, while maintaining the vacuum on the system to begin the process of drawing out excess fluid.



If you are re-using a previous diaphragm, it will take time for the silicone fluid to migrate through the system, be patient!

8. Release the vacuum, and remove both the fill tube and the vacuum pump from the fittings.

Continues next page...

9. Empty the fill tube of fluid, and place it on the fitting near the switch, extending upwards, open to the atmosphere.
10. Ensure that the eccentric box of the pump has been filled to the appropriate level with the correct (normally Pulsalube 7H™) hydraulic fluid.
11. Adjust the pump to the zero stroke (0%) position.
12. **If the pump is not already hydraulically primed**, remove the PTP valve from the top of the pump head. Using a plastic funnel or similar, slowly pour hydraulic fluid into the pump head cavity until full.
13. Inspect the PTP valve to ensure the sealing o-ring is still in position, and re-install the valve.
14. Adjust the pump to full (100%) stroke.
15. In order to fully balance and evacuate the leak detection system, the pump must now run at normal discharge pressure for a period of one hour. This ensures that excess barrier fluid is fully evacuated from the system.
16. Supply either process fluid, or test fluid (i.e. water) to the suction fitting and ensure that the discharge system is configured for safe operation. The pump can be started with minimal discharge pressure and then slowly brought up to full pressure, if the system allows for this.
17. Apply power and start the pump. Hold down the PTP valve momentarily and observe the middle port under the diagnostic cover. If no fluid is coming from this port, stop the pump and return to step 11. If fluid is present, continue to step 18.
18. Slowly increase the discharge pressure to full operating pressure, and continue to run the pump for a period of one hour.
19. During this time, excess barrier fluid will be displaced from the system into the short length of tubing attached to the exit port, balancing the system for proper operation. A small pen mark on the tube can assist in observing this process visually.
20. After the one-hour startup period, remove the tubing and connection from the housing body and reinstall the pressure gage. Remove the fitting from the fill port and replace with the supplied pipe plug.
21. Reconnect the alarm switch to the external system if necessary.
22. The pump and pressure leak-detection system are now properly prepared and ready for normal service. During normal operation, the gauge should indicate 0 (zero) pressure.



**Under certain circumstances, the system may not completely evacuate excess barrier fluid during the procedure as outlined above. In these cases, after several days run time, a small amount of pressure may build in the system. If this occurs, simply loosen the pressure gauge from the switch housing and relieve a small amount of barrier fluid, returning the system to a zero-pressure state.**



**Once this startup procedure is completed, the pressure leak detection system should require no further maintenance.**

## 11.6 Leak Detection System Maintenance



Although the PULSAlarm leak detection system requires minimal maintenance, vacuum must be maintained to prevent false alarms and diaphragm damage.

### 11.6.1 Vacuum Setpoint Adjustment

If the optional switch is purchased, it is factory preset at the specified vacuum setpoint, 150 mm Hg (6 in. Hg), at which loss of vacuum causes the vacuum switch to actuate. The standard pressure switch is set to actuate at 5 psig.

**Use the following procedure to perform a Vacuum setpoint adjustment:**

1. Disconnect the alarm circuit from the vacuum switch.
2. Remove the switch enclosure cover and loosen the knurled locking ring on the switch.
3. Rotate the hex adjusting ring counterclockwise to increase or clockwise to decrease the setpoint.
4. Verify the new setpoint (refer to the next section).
5. Repeat steps (3) and (4) above until the required setpoint is attained.
6. Tighten the switch locking ring and replace the switch enclosure cover.
7. Reconnect the alarm circuit to the vacuum switch.

**Use the following procedure to perform a setpoint adjustment test**

1. Evacuate the system to approximately 650 mm Hg (26 in. Hg) OR properly prime and prepare the pressure system.
2. Remove the switch cover and connect ohmmeter leads across the common terminal and the other terminal used in operation (NO or NC).
3. Record the status of the switch (open or closed).
4. a. Vacuum: Break the vacuum system at any point external to the pump to permit gradual loss of vacuum.  
b. Pressure: remove the pressure gauge, and install a hand pump or other means of producing a small amount of pressure in the system.
5. Observe the ohmmeter to detect actuation.

**The setpoint can be observed by reading the vacuum/pressure gauge upon actuation.**

## 11.7 PULSAlarm Leak Detection Diaphragm Maintenance



After diaphragm failure, pressurized process fluid can be present in any part of the PULSAlarm leak detection vacuum system. Take appropriate precautions and handle with care.

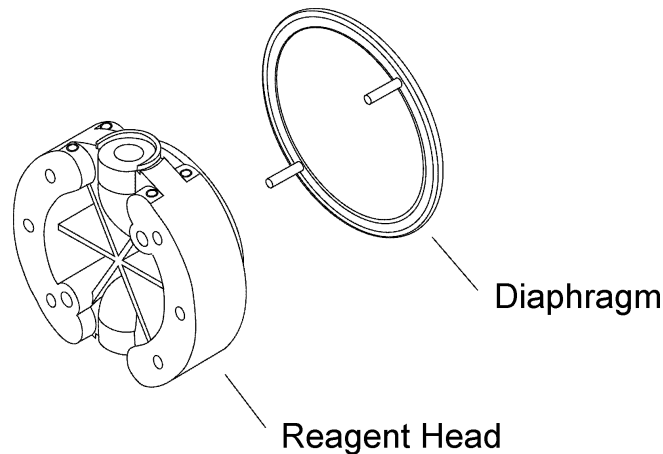

Figure 27

### 11.7.1 Leak Detection Diaphragm Removal

Use the following procedure to remove the Leak Detection Diaphragm:

1. Disconnect the power source to the drive motor.
2. Relieve all pressure from the piping system, and close the inlet and outlet shutoff valves
3. Take all precautions to prevent environmental and personnel exposure to hazardous materials.
4. Place a suitable container underneath the pump head to catch any liquid leakage.
5. Disconnect process piping and drain any process liquid, following material safety precautions.
6. Remove all but one top reagent head bolt. Oil will leak out between the pump head and reagent head as the bolts are loosened.
7. Tilt the head and pour out any liquids retained by the check valves into a suitable container, continuing to follow safety precautions as appropriate.
8. Remove the alarm switch assembly or pressure gauge from the reagent head.
9. Remove the bleed valve assembly and flat gasket from the reagent head.
10. Rinse or clean the reagent head with an appropriate material.
11. Remove the diaphragm by running a blunt blade along the periphery and prying it out.

## 11.7.2 Inspection

Remove and inspect the diaphragm assembly. It may have taken a permanent convex/concave set as a result of normal flexure and conformance to the dish-plate. This condition is normal and is not cause for replacement. The diaphragm must be replaced if it is deformed, dimpled, or obviously damaged.



**If the diaphragms have been removed from the spacer ring, the entire assembly should be replaced to ensure proper sealing of its components.**

## 11.7.3 Leak Detection Diaphragm Reinstallation

1. Ensure that the critical sealing areas of diaphragm assembly, reagent head, and pump head are clean and free from debris. Align the diaphragm assembly capillary tubes with mating holes in the seal groove in the reagent head and position it in place against the reagent head. Ensure seating of the diaphragm sealing ring into the mating groove in the reagent head.
2. Install the reagent head bolts and tighten in an alternating pattern to ensure an even seating force. Torque to the values recommended in *Appendix IV*.
3. Apply sealing compound to the gauge/pressure switch assembly and reinstall to the upper port on the reagent head.
4. Apply sealing compound to the fill valve assembly and reinstall to the lower port on the reagent head.
5. Open the needle valve
6. Connect a hand-held vacuum pump or other vacuum source to the vacuum port, which fits 6 mm (1/4 in.) I.D. tubing.
7. **For a vacuum system, evacuate to approximately 650 mm Hg (26 in. Hg) and securely tighten the needle valve after evacuation.** Diaphragm damage or decreased flow will occur if a vacuum is not drawn before the pump is returned to service. Refer to section 11.1 “Setup for Vacuum”.
8. Re-prime the pump head hydraulic system, see Section 7.2.2 on page 18
9. **For a pressure system, see section 11.5, “Pressure System Set-up and Priming”**
10. If required, test vacuum or pressure system operation.
11. After diaphragm set-up and priming, the pump is ready to be returned to service.

## 11.8 Leak Detection system conversion

Leak detection system conversion information can be found in Bulletin CV-LD-0203 (vacuum to pressure system). For further conversion information and kits, please contact your local Pulsafeeder sales representative.

# 12. Appendix II Piping Calculations

## Suction Head Requirements

All reciprocating metering pumps require a net positive suction head (NPSHR). Refer to Table 1 for the (NPSHR) required for PULSAR pump models. The NPSHR is defined as the pressure required above the absolute vapor pressure of the process fluid at the pumping temperature. This pressure is required at the suction port of the pump throughout the entire pump stroking cycle in order to prevent cavitation of the process fluid within the reagent head. The NPSHR is one of the requirements necessary to assure metering accuracy.

**Table 1. NPSH<sub>R</sub> values**

NPSH <sub>R</sub>	PULSAR
English (psi)	3
Metric (bar)	0.21

The net positive suction head available (NPSH<sub>A</sub>) must be greater than the NPSH<sub>R</sub>. The NPSH<sub>A</sub> of any given system is calculated as follows for comparison to the NPSH<sub>R</sub> as shown in Table 1.

Equation 1. – For fluid viscosity below 50 centipoise.

$$NPSH_A = P_A \pm P_H - P_V - \left( \frac{L_s R G Q}{C_1 d^2} \right)$$

Equation 2. – For fluid viscosity above 50 centipoise.

$$NPSH_A = P_A \pm P_H - P_V - \sqrt{\left( \frac{L_s R G Q}{C_1 d^2} \right)^2 + \left( \frac{L_s \mu Q}{C_2 d^4} \right)^2}$$

The variables used in the previous Equations must be in the units shown in Table 2 for the constants listed to be used correctly.

**Table 2. Unit sets and constant values for use in NPSH Equations.**

Variable	Units Set	
	English	Metric
NPSH	psi	bar
$P_A$	psia	bar(a)
$P_H$	psi	bar
$P_V$	psia	bar(a)
$L_S$	feet	meters
R	strokes/min	strokes/min
G	no units	no units
Q	gallons/hr	liters/hr
d	inches	millimeters
$\mu$	centipoise	centipoise
$L_D$	feet	Meters
$P_T$	psi	bar
$P_P$	psi	bar
$V_P$	feet/sec	meters/sec
$C_1$	24,600	640
$C_2$	45,700	1.84
$C_3$	46.8	0.91



If piping sizes vary throughout the suction line, different additive values may be used for the pressure losses attributed to the liquid's acceleration and deceleration. Use the last term of Equation 1 or 2 as many times as needed in the equation to adjust for different lengths of different pipe diameters in the suction line. (Everything but the pipe length and diameter will stay the same in the equation.)

All reciprocating metering pumps also require that a minimum absolute pressure and minimum suction head (MSH), be maintained at the pump inlet throughout the pumping cycle to ensure a stable hydraulic system and proper pump operation. The sum of the  $NPSH_A$  and the vapor pressure ( $P_V$ ) must be greater than the values shown in Table 3.

**Table 3. Minimum values for the sum of  $NPSH_A$  and vapor pressure. (MSH)**

MSH	PULSAR	PULSAR*
English, (psia)	5	7.5
Metric, (bar(a))	0.35	0.53

\* PULSAR Pump with PULSAlarm leak detection diaphragm.

## System Back Pressure

The system backpressure must exceed the suction pressure by at least 5 psi (0.35 bar) in order to prevent flow through, however it must not exceed the rated discharge pressure of the pump. Flow through can be defined as the process liquid flowing from a higher pressure to a lower pressure (downhill pumping), which attributes to pump failure and undesired flow at pump shutdown. If the system backpressure is not at least 5 psi (0.35 bar) greater than the suction pressure, a backpressure valve must be installed in the discharge piping. To calculate the system's total backpressure use Equation 3 or 4.

Equation 3. – For fluid viscosity below 50 centipoise.

$$P_T = \left( \frac{L_s R G Q}{C_1 d^2} \right) + P_P \pm P_H$$

Equation 4. – For fluid viscosity above 50 centipoise.

$$P_T = \sqrt{\left( \frac{L_s R G Q}{C_1 d^2} \right)^2 + \left( \frac{L_s \mu Q}{C_2 d^4} \right)^2} + P_P \pm P_H$$

## Nomenclature

NPSH <sub>R</sub>	=	Net positive suction head required, [psi, bar]
NPSH <sub>A</sub>	=	Net positive suction head available, [psi, bar]
P <sub>A</sub>	=	Pressure at the surface of the liquid being pumped (atmospheric or supply tank blanket pressure) [psi(a), bar(a)]
P <sub>H</sub>	=	Head pressure above (+) or below (-) the pump centerline, [psi, bar,] (convert from ft or m)
P <sub>V</sub>	=	Absolute vapor pressure at pumping temperature of the process liquid at pump inlet, [psi(a), bar(a)]
L <sub>S</sub>	=	Length of suction piping (actual, not equivalent), [ft, m]
R	=	Pump stroking rate, strokes/min [spm]
G	=	Specific gravity of process liquid, [no units]
Q	=	Pump average flow rate, [gph, lph]
d	=	Internal pipe diameter, [inches, mm]
C1, C2, C3	=	Numeric constants used in Equations 1 - 4 [no units]
μ	=	Viscosity of process liquid at pumping temperature, centipoise [cp]
L <sub>D</sub>	=	Length of discharge piping (actual, not equivalent), [ft, m]
P <sub>P</sub>	=	System discharge pressure, [psi(g), bar(g)]
P <sub>T</sub>	=	Peak pump discharge pressure at the discharge port, [psi(g), bar(g)]
V <sub>P</sub>	=	Peak liquid velocity generated by the pump, (suction or discharge) [ft/s, m/s]

## 13. Appendix III Oil Specifications

### ***PULSA*lube # 7H**

API Gravity (ASTM D 287) = 31  
Viscosity (ASTM D 2161) SSU @ 100° F = 175  
Viscosity (ASTM D 2161) SSU @ 210° F = 51  
Viscosity Index (ASTM D 2270) = 193  
Pour Point (ASTM D 97) Degrees F (C) = -60(-51)  
Flash Point, COC (ASTM D 92) Degrees F (C) = 367(186)  
Fire Point, COC (ASTM D 92) Degrees F (C) = 403(205)  
Color = purple

### ***PULSA*lube # 8G**

AGMA Number = 7 EP  
ISO Viscosity Grade = 460  
API Gravity (ASTM D 287) = 34.1  
Viscosity (ASTM D 2161) SSU @ 100° F = 2241  
Viscosity (ASTM D 2161) SSU @ 210° F = 225  
Viscosity Index (ASTM D 2270) = 167  
Pour Point (ASTM D 97) Degrees F (C) = -40(-40)  
Flash Point, COC (ASTM D 92) Degrees F (C) = 490(254)  
Timken OK Load (ASTM D 2782) Lb(kg) = 100+(45+)  
Four Ball EP Test (ASTM D 2783)  
Weld Point kg = 250  
Load Wear Index = 47  
Rust Test (ASTM D 665A&B) = Pass  
Oxidation Test (ASTM D 2893) = Pass  
Demulsibility Test (ASTM D 2711) = Pass  
Foam Test (ASTM D 892) = Pass  
Copper Corrosion (ASTM D 130) = 1-A  
Color = amber

# 14. Appendix IV Bolt Torque Recommendations

## Metal Construction

Reagent Head Part No.	Head Size	Head Bolts			Tie bar Bolts		
		No. Bolts & Size	Torque		No. Bolts & Size	Torque	
			N-m	Ft-lbs.		N-m	Ft-lbs.
NP160001	A	(6) M10 * 1.5	39	29	(4) M8 * 1.25	8	6
NP160002	B	(6) M12 * 1.75	68	50	(4) M8 * 1.25	8	6
NP160003	C	(6) M10 * 1.5	39	29	(4) M8 * 1.25	8	6
NP160004	D	(6) M8 * 1.25	20	15	(4) M8 * 1.25	8	6

## Plastic Construction

Reagent Head Part No.	Head Size	Head Bolts			Tie bar Bolts		
		No. Bolts & Size	Torque		No. Bolts & Size	Torque	
			N-cm	In-lbs.		N-cm	In-lbs.
NP160012	A	(6) M10 * 1.5	850	75	(4) M8 * 1.25	250	22
NP160014	B	(6) M12 * 1.75	850	75	(4) M8 * 1.25	250	22
NP160011	C	(6) M10 * 1.5	850	75	(4) M8 * 1.25	250	22
NP160013	D	(6) M8 * 1.25	850	75	(4) M8 * 1.25	250	22

Please note that torque values for plastic heads are given in N-centimeters and inch-lbs

# 15. Appendix V Pulsafeeder Accessories

## Pulsatrol Installation, Operation, & Removal Instructions

The PULSAtrol is a pneumatically charged diaphragm-type chamber that intermittently stores energy. Used on the inlet, it will improve NPSHA (Net Positive Suction Head available) characteristics of the suction piping system. On the discharge line it will reduce peak pressures and pulsating flow variations.

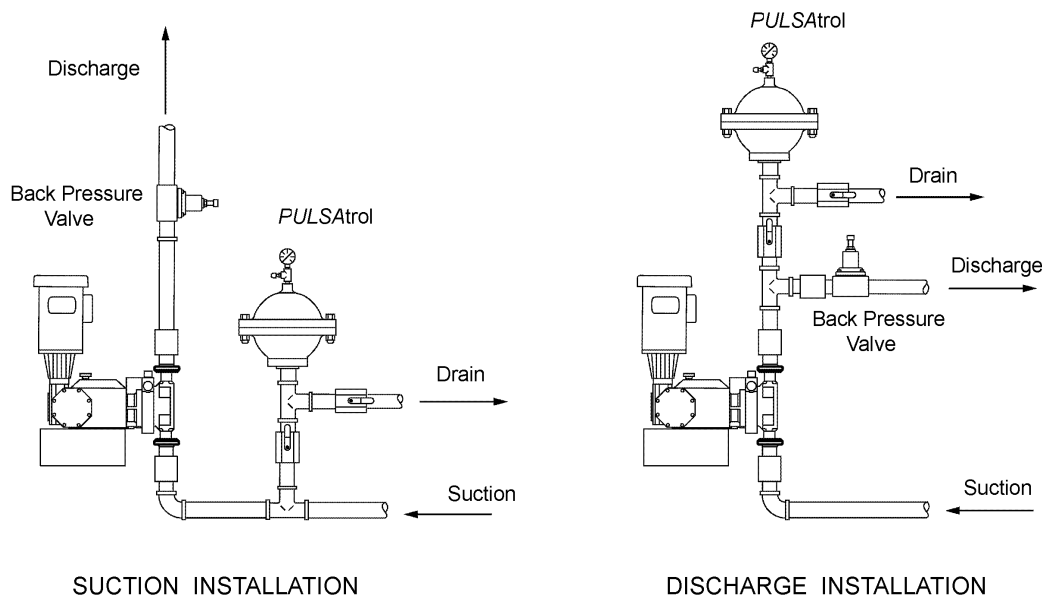

Figure 28

## Installation

On both discharge and suction lines, it is desirable to mount the *PULSATrol* as close to the pump connection as possible. It can be mounted in any position: horizontally, vertically, or at any angle. A shutoff valve should always be used between the piping system and *PULSATrol*. If the discharge line is open to atmospheric pressure, a backpressure valve should also be incorporated in the system near the *PULSATrol* to assure proper operation. Pulsation dampeners do require regular maintenance and inspection. Charge pressure should be checked every 2-4 months and renewed as needed. Temperature, pressure, and other variables will affect charge life and diaphragm/bladder life.

### A) Discharge Setup

The *PULSATrol* may be precharged with air or nitrogen. When properly precharged the diaphragm is positioned against the bottom liquid chamber. It is therefore necessary to drain all liquid below the diaphragm and vent to atmospheric pressure when precharging.

Use the precharge pressure as determined from the *PULSATrol* selection and sizing procedure (Catalog No. 211). This can vary from 50 to 80% of mean line pressure in accordance with fluctuation level selected. The *PULSATrol* is now ready for service and the diaphragm will move to a neutral position as liquid enters the chamber.

#### Use the following to complete a Pre Charge Procedure for Discharge Installation

1. Calculate the precharge pressure
  - a) Mean Line Pressure (PSIG) + Atmospheric Pressure = Absolute Pressure (PSIA)
  - b) Absolute Pressure (PSIA)  $\times$  Precharge Percentage (80% max) = Pressure Absolute
  - c) Pressure Absolute – Atmospheric Pressure = Precharge Pressure (PSIG)
2. Isolate *PULSATrol* from line.
3. Carefully drain off process fluid by opening a drain valve (see recommend piping arrangement).
4. Apply precharge pressure (additional liquid may drain as diaphragm moves).
5. Close drain valve.
6. Place *PULSATrol* in stream.

### B) Suction Setup (Flooded Suction)

Charge the *PULSATrol* with adequate pressure to overcome the static suction head. Start up the pump. Depress the stem on the charge valve, but only during discharge strokes of the pump, until the gauge indicates pressure pulses. The diaphragm has now centered allowing the *PULSATrol* to accumulate liquid while the pump is discharging. If too much air becomes released and the gauge will not indicate pressure pulses, recharge the *PULSATrol* and repeat the procedure.

#### Use the following to complete a Pre Charge Procedure for Suction Installation

1. Isolate accumulator from line.
2. Carefully drain off process fluid by opening a drain valve (refer to *Figure 24*).
3. Apply 5-10 psi precharge pressure (additional liquid may drain as diaphragm moves).
4. Close drain valve.
5. Bleed off all pressure on the *PULSATrol*.
6. Open the valve to put *PULSATrol* in stream.
7. Push in on the stem of the charging valve during the discharge stroke of the pump and release during the suction stroke.
8. Continue this for about 10 times and observe the compound gauge. As accumulator functions, the needle will go from pressure to vacuum.

## PULSAtrol Removal

When removing or disassembling a *PULSA*trol, drain all piping and remove all air and process pressure. Assume that the diaphragm is broken and the chamber is flooded under pressure since the pressure gauge could be damaged. Separate chambers with caution in a direction away from the body.

## Back Pressure Valve

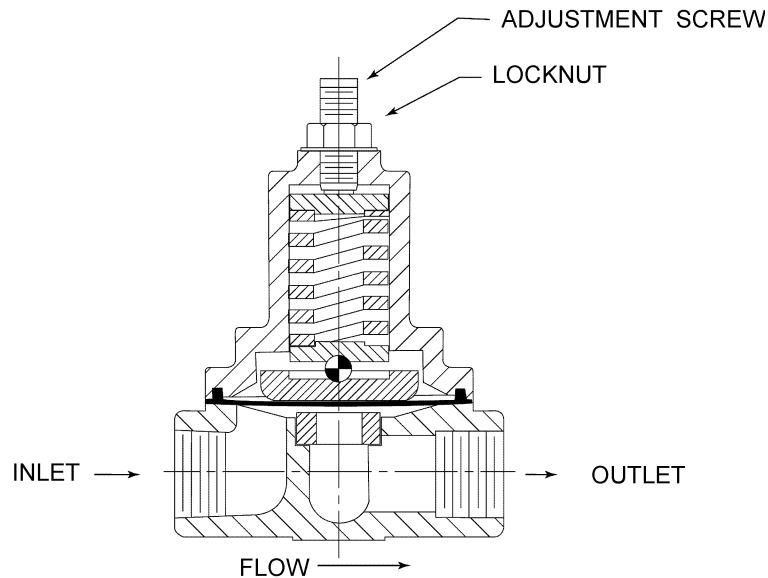

Figure 29

The Pulsafeeder diaphragm backpressure valve creates constant backpressure. A TFE diaphragm, offering maximum chemical protection and service life, seals spring and bonnet from product. This diaphragm seals directly on a replaceable seat.

Be sure to install with fluid flow in direction of arrow on valve body. If arrow is missing from plastic valve body, install with flow exiting out center hole of valve body.

## Pressure Relief Valve

Pressure relief valves should be utilized in any system to protect the pump and other process equipment and piping from potentially damaging or unsafe pressures. It is critical that the pressure relief valve be mounted in the discharge piping system before any other devices that can potentially block or impede flow, or it cannot perform its intended function (refer to *Figure 8*).

The pressure relief valve must be set to a pressure high enough to prevent unwanted fluid relief during normal process conditions. A setting that is approximately 10-20% above normal operating pressures is generally sufficient. The valve must also be set below the maximum pressure capability of the lowest rated device in the system. For example, if a PULSAR pump is rated with a maximum pressure capability of 150 psi (approx. 10 bar) but the piping within the system is rated only to a maximum of 100 psi (approx. 7 bar) then the pressure relief valve must be set to a value lower than 100 psi.

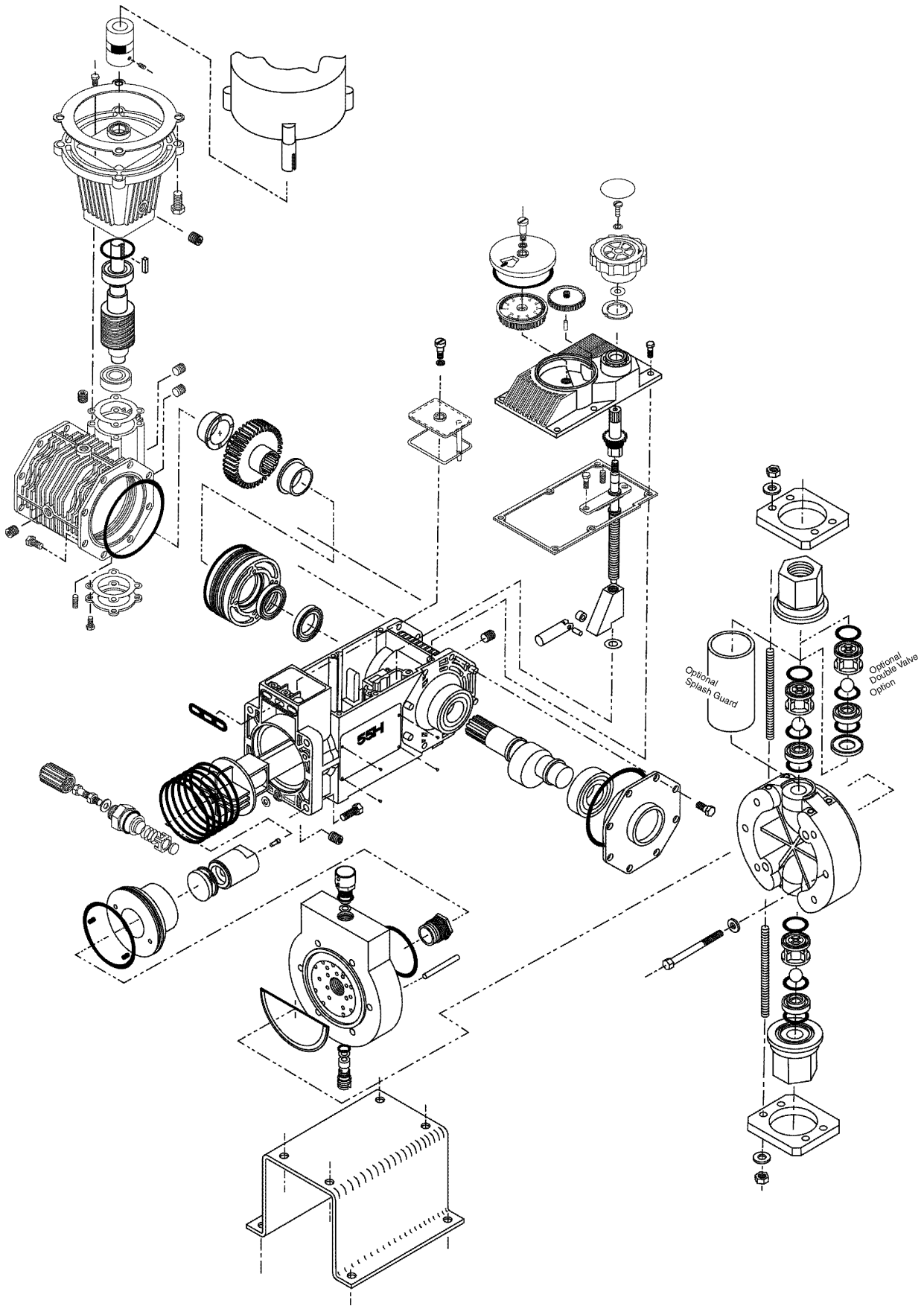





Engineered Pump Operations  
2883 Brighton-Henrietta Townline Road  
Rochester, NY 14623  
Telephone (585) 292-8000 Fax (585) 424-5619  
[www.pulsa.com](http://www.pulsa.com) [pulsa@idexcorp.com](mailto:pulsa@idexcorp.com)

12 - 2006  
Bulletin PR-IOM-0802  
Rev D